

Structure-Transport Relationship in Organized Soft Matter Systems by Diffusion NMR

Sergey Vasenkov

Outline

- Combining advantages of high field and high gradients in diffusion NMR
- Relationship between diffusivities of ions and their sizes in ionic liquids with and without absorbed species
- Exchange of lipids between liquid-ordered and liquid-disordered domains in planar-supported lipid bilayers

Pulsed field gradient (PFG) NMR



"OK, I hope we can put them back, as they were"

© Mike Barlow/Corbis

A non invasive technique....the sample is un-tampered!

Can probe diffusion for time scales: 1 ms to seconds
length scales of displacements: 90 nm to 100 μ m

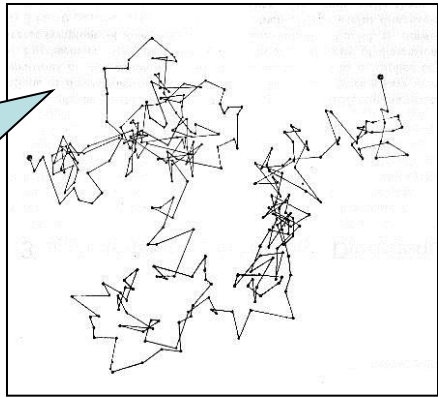

- The spatial resolution depends on the strength of the magnetic field gradients
- Application of high (up to 30 T/m) gradients allows investigating transport on submicrometer length scales of displacements

Pulsed field gradient (PFG) NMR

- Nuclear spins precess around the direction of the external magnetic field with the Larmor frequency ω_L
- PFG NMR: Magnetic field gradient pulses are superimposed on the on the constant uniform magnetic field

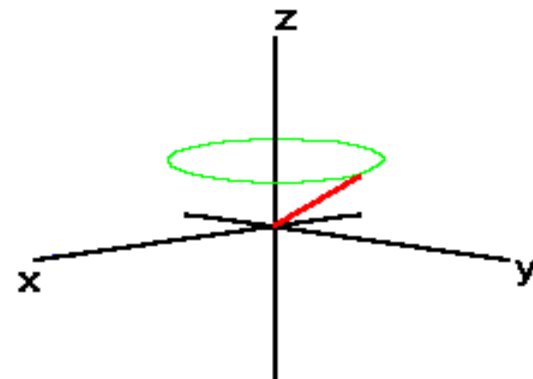

$$\omega_L = \gamma B_0$$



$$\omega_L(z) = \gamma(g(t)z + B_0)$$

PFG NMR Stimulated Echo Pulse Sequence

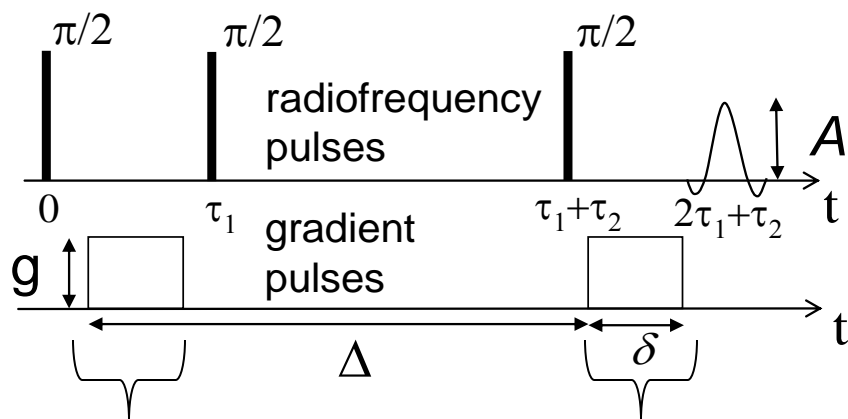

In the de-phasing time interval position of each spin is labeled by the phase accumulated in the local field

$$\varphi = \gamma \int_0^{\tau_1} (g(t)z_1 + B_0) dt$$

The spins are unlabeled in the re-focusing interval

$$\Delta\varphi = \gamma \left(\int_0^{\tau_1} (g(t)z_1 + B_0) dt - \int_{\tau_1+\tau_2}^{\tau_1+\tau_2+\tau_1} (g(t)z_2 + B_0) dt \right)$$

$$\Delta\varphi = \gamma\delta g\Delta z$$

Pulsed field gradient (PFG) NMR

The measured signal $A(g)$ is reduced due to displacements of studied molecules

$$\Psi \equiv \frac{A(g)}{A(g=0)} = \exp\left(-\frac{1}{6}(\gamma\delta g)^2 \langle r^2(t_{eff}) \rangle\right) = \exp\left(-(\gamma\delta g)^2 D t_{eff}\right),$$

$$A \propto \exp\left\{-\frac{2\tau_1}{T_2} - \frac{\tau_2}{T_1}\right\}$$

$$\langle r^2(t_{eff}) \rangle = 6Dt_{eff}.$$

$$t_{eff} = \Delta - \frac{\delta}{3}$$

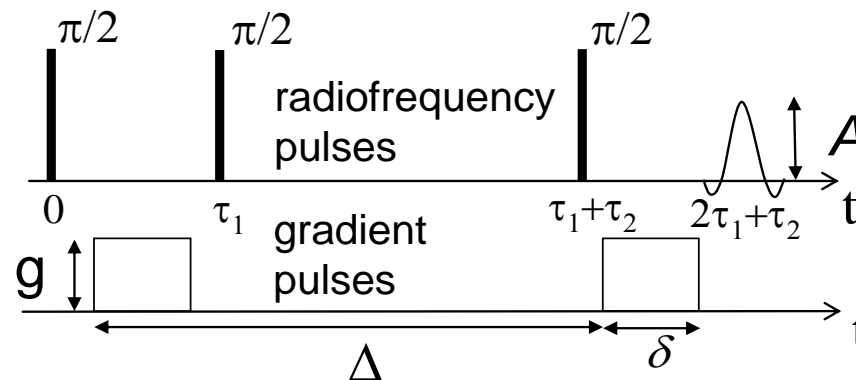

17.6 T Magnet



- **Up to 30 T/m pulsed gradients (diff60 probe)**
- **Frequency domain diffusion measurements**
- **Multinuclear diffusion NMR**

Room temperature ionic liquids

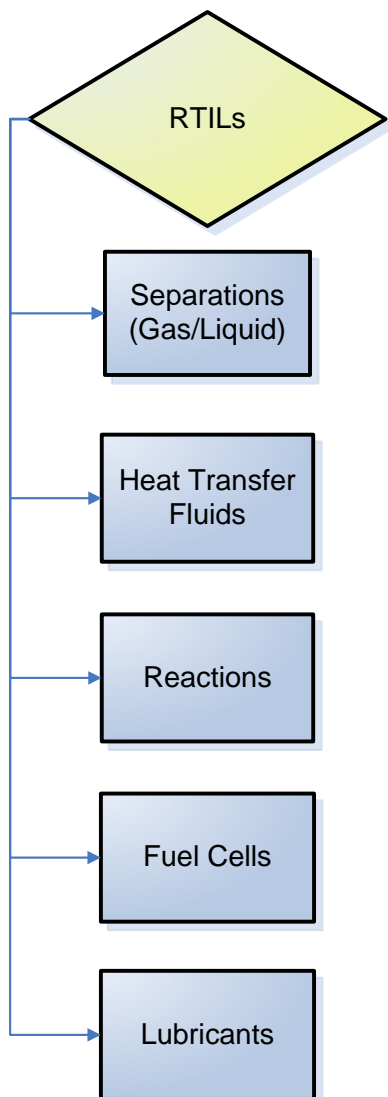

- ✓ Good solvents
- ✓ Negligible vapor pressure
- ✓ Liquids over a large temperature range
- ✓ High ionic conductivity, thermal stability
- ✓ Properties can be tailored

Not much data are available on translational dynamics in mixtures of ionic liquids with water or CO₂



Thousands of papers published in last decade

^1H NMR spectra

Cation: 1-ethyl-3-methylimidazolium
[emim]

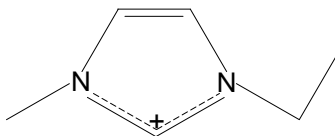

Anion: ethylsulfate
[EtSO₄]

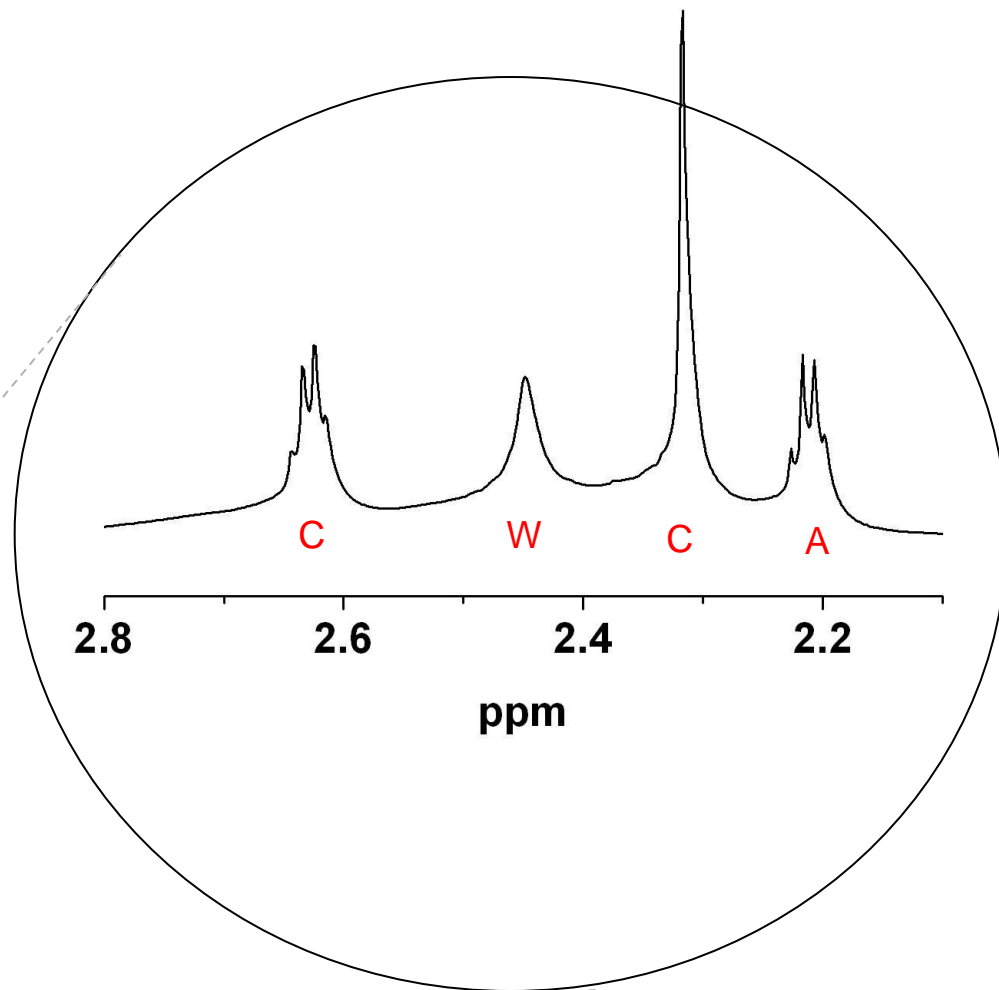
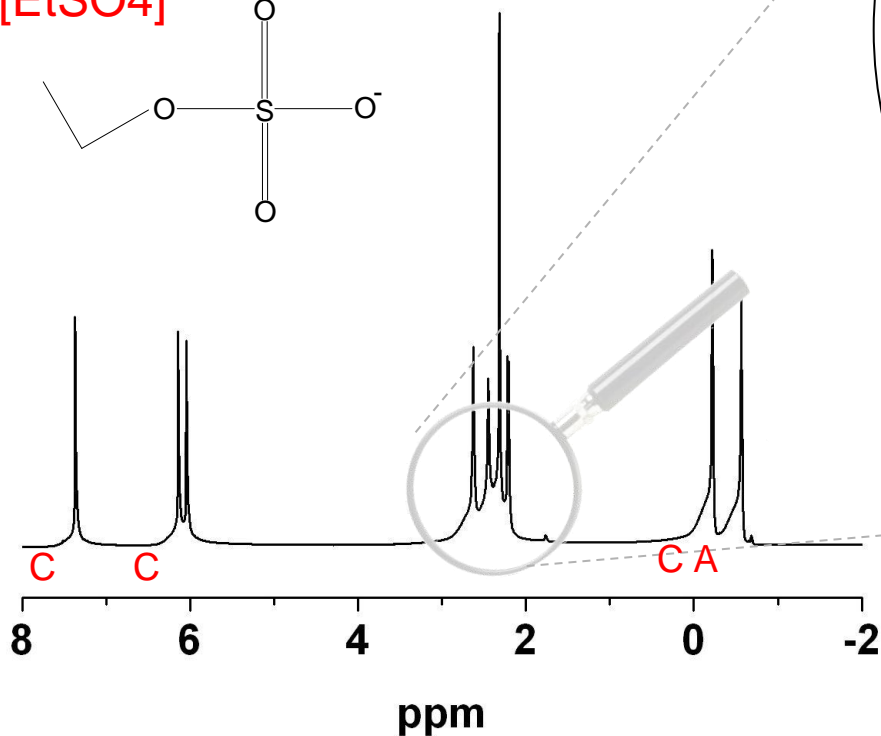
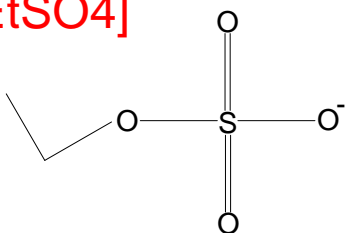

*^1H NMR Spectra obtained
by PFG STE pulse sequence*

¹H PFG NMR attenuation curves

- Signal intensity = area under selected NMR lines

- Straight Lines ↔ Single Diffusivity

$$\Psi = \exp(-\gamma^2 \delta^2 g^2 D t_{eff})$$

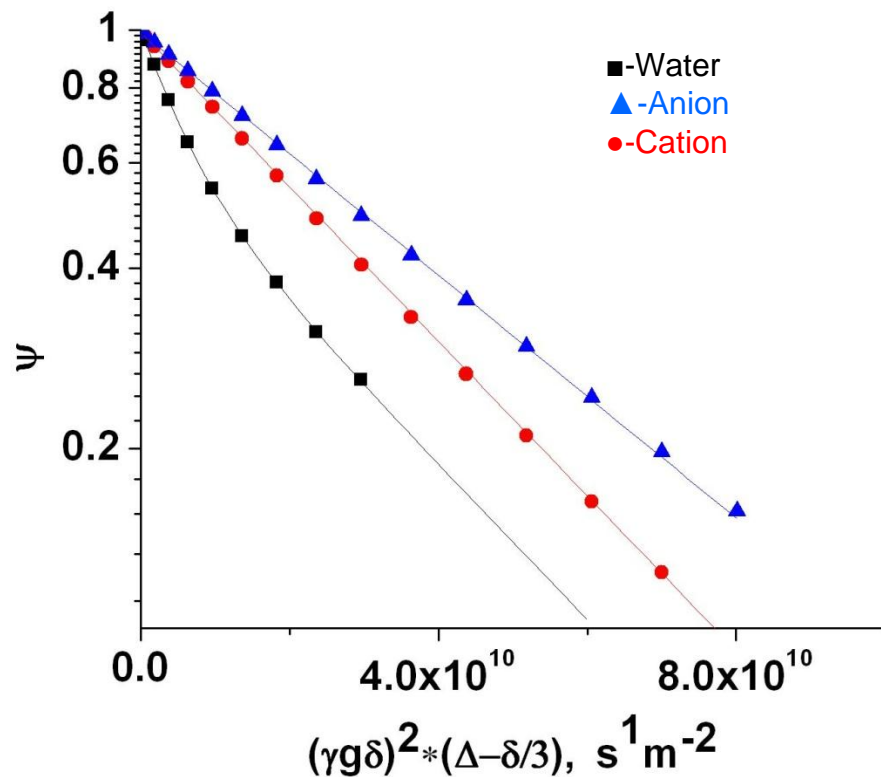

¹H PFG NMR attenuation curves for [Emim][ETSO₄] for 49.5% water at 298K

Relationship between the diffusivities of the bulkier [Emim] cation and that of the less bulky [ETSO4] anion

X - [Emim]⁺ o - [ETSO4]⁻ ■ - Water

MD data from M.S. Kelkar, W. Shi, E.J. Maginn, *Ind. Eng. Chem. Res.*, 47 (2008) 9115.

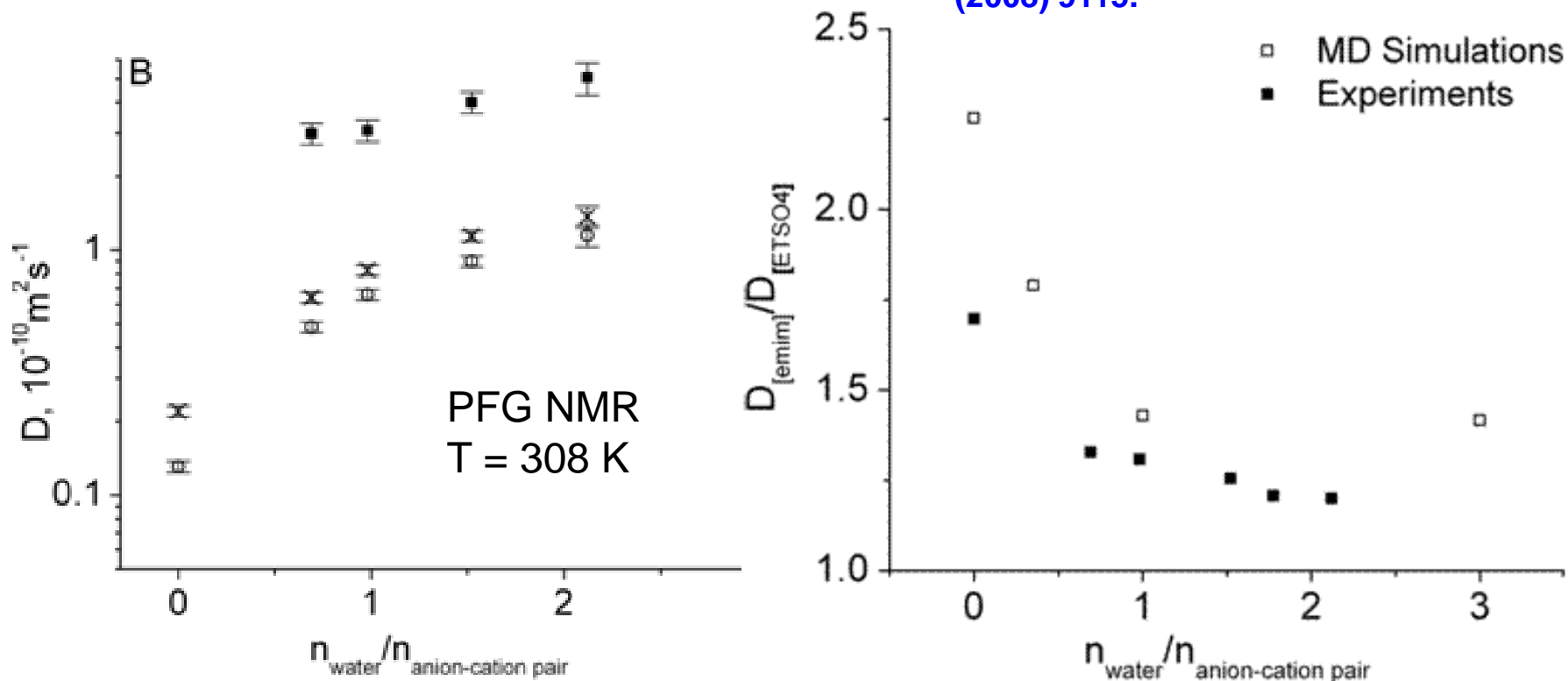

Suppression of the anomalous relationship between the diffusivities of the cation and anion in [Emim][ETSO4] due to addition of water

Influence of water on nanostructure

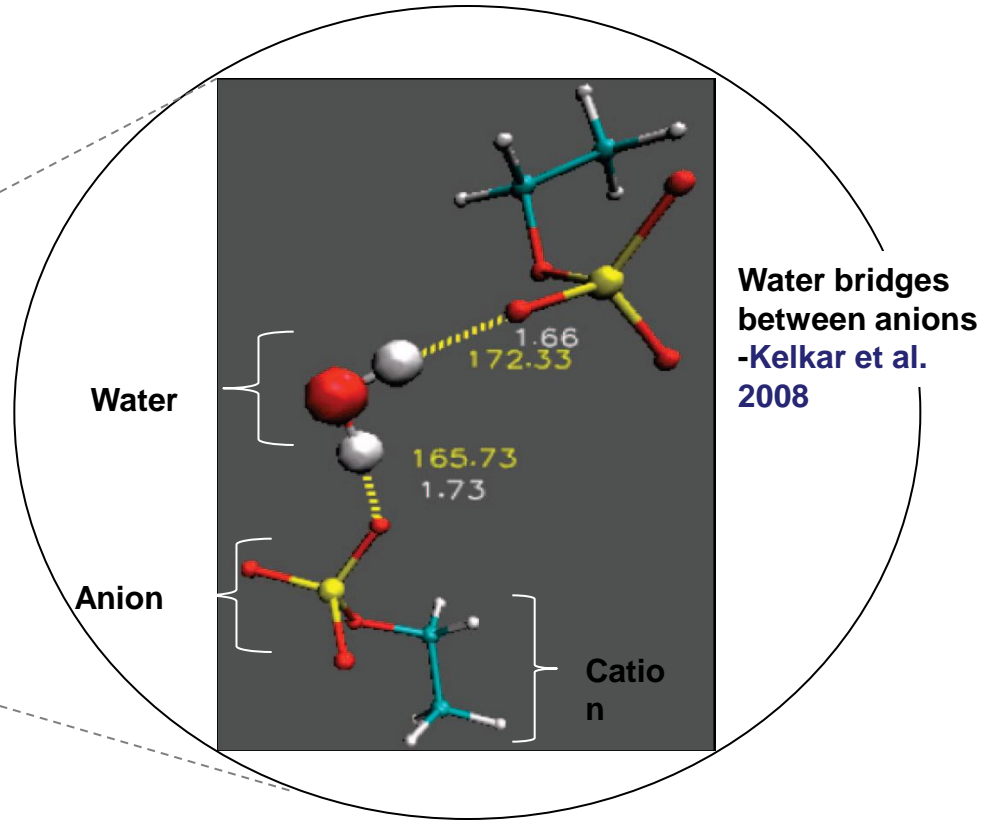
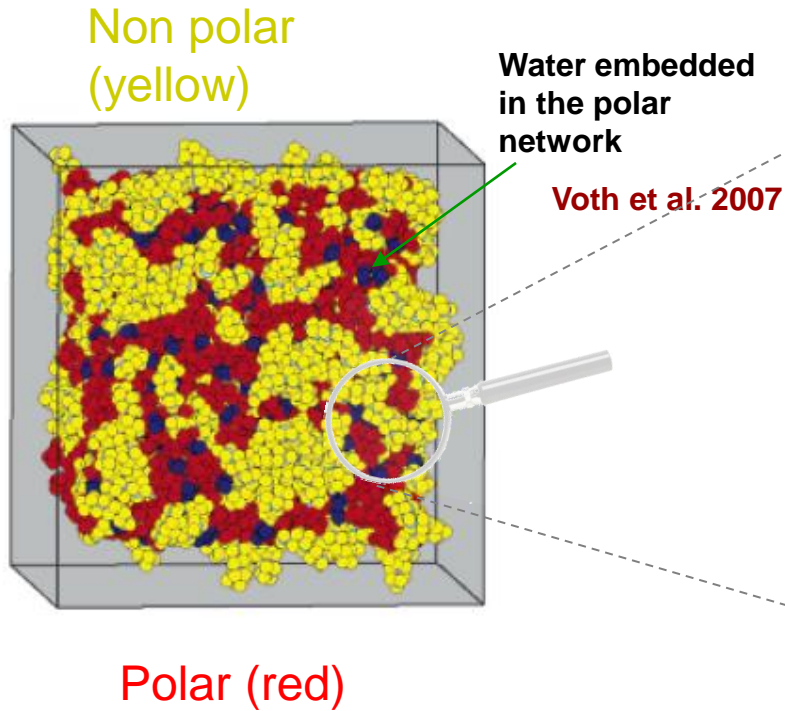

Well-defined local structure in the water-free IL results in a cooperative character of ion diffusion and even in an appearance of diffusion anisotropy for the cation diffusion.

Addition of water makes local structure more fluid and less defined

Influence of water content on the activation energy of diffusion

- - [Emim]
- ▲ - [ETSO4]
- - Water

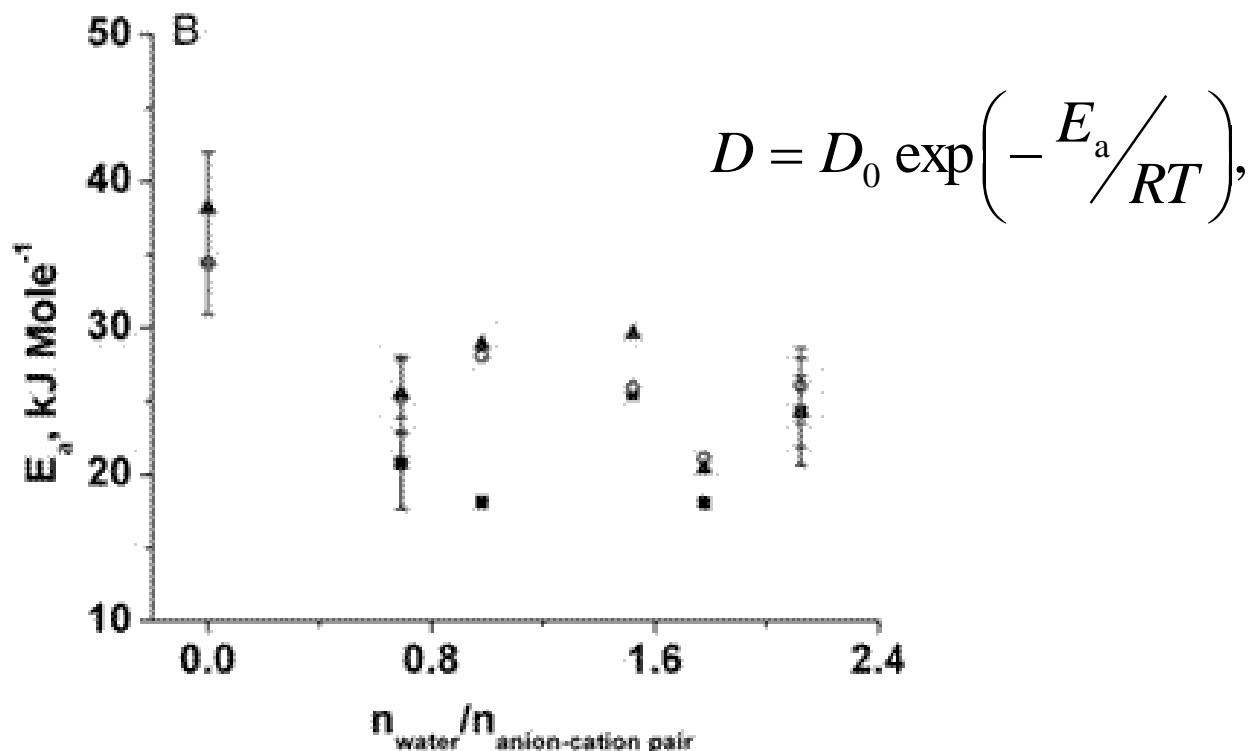

Significant decrease in the activation energy of diffusion due to addition of water

^{13}C NMR spectrum

1-n-butyl-3-methylimidazolium bis(trifluoromethylsulfonyl)imide ([bmim] [Tf₂N]) + 0.01 CO₂ molecules per cation/anion pair

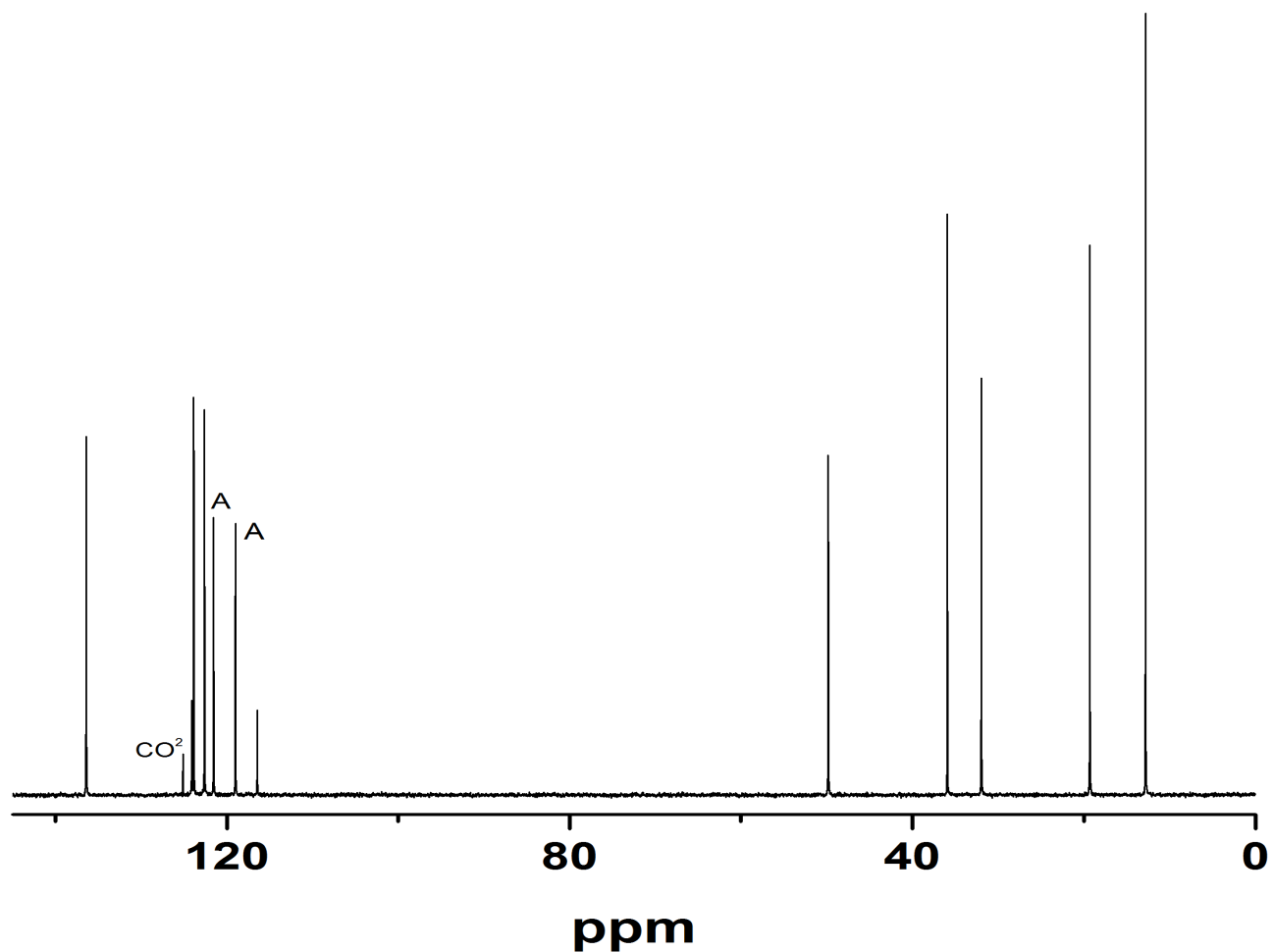

^{13}C PFG NMR diffusion data

- [bmim] cation
- ▲ [Tf2N] anion
- CO_2

T = 297 K

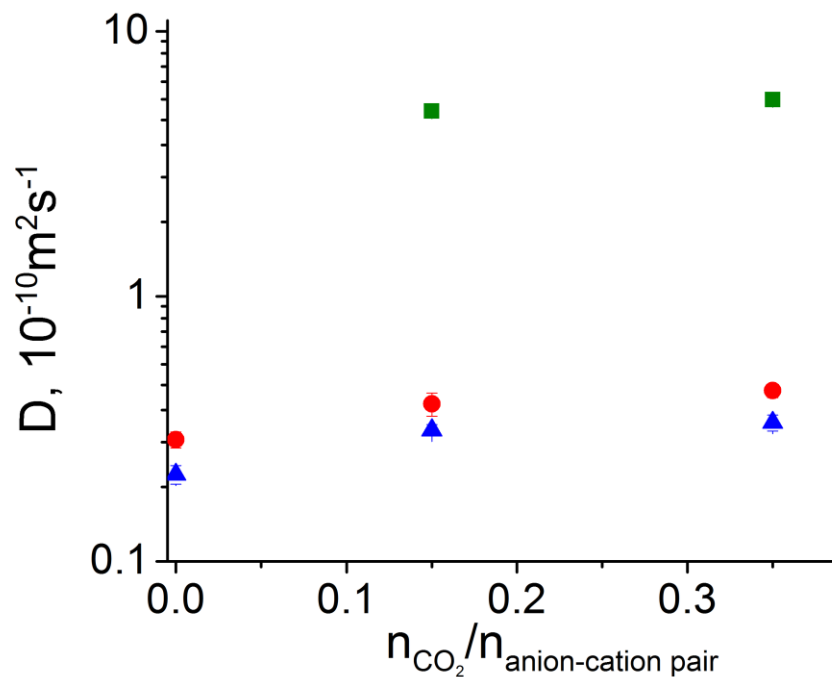
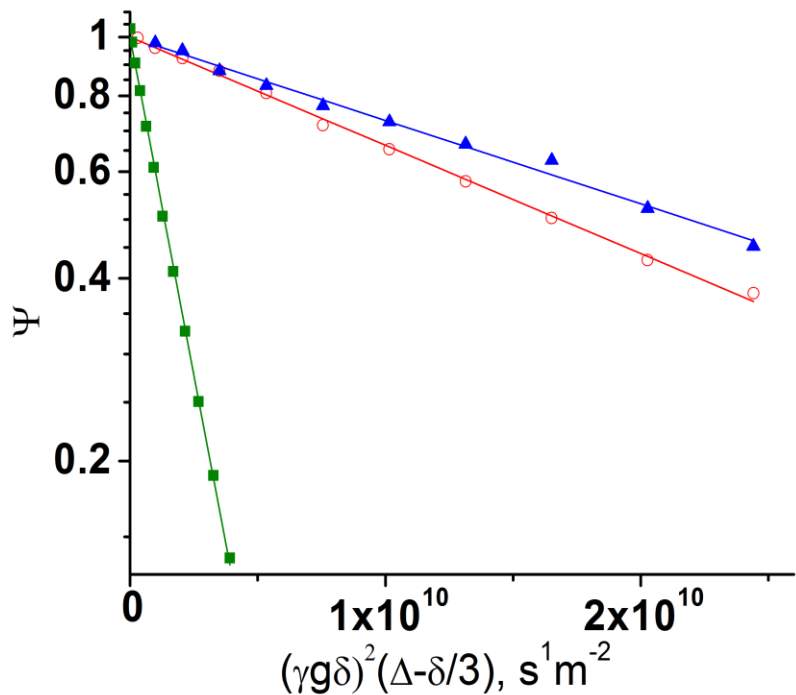

Anomalous relationship between the diffusivities of the cation and anion in [bmim][Tf2N] is not visibly affected by CO_2 absorption

Domains in protein-lipid membranes

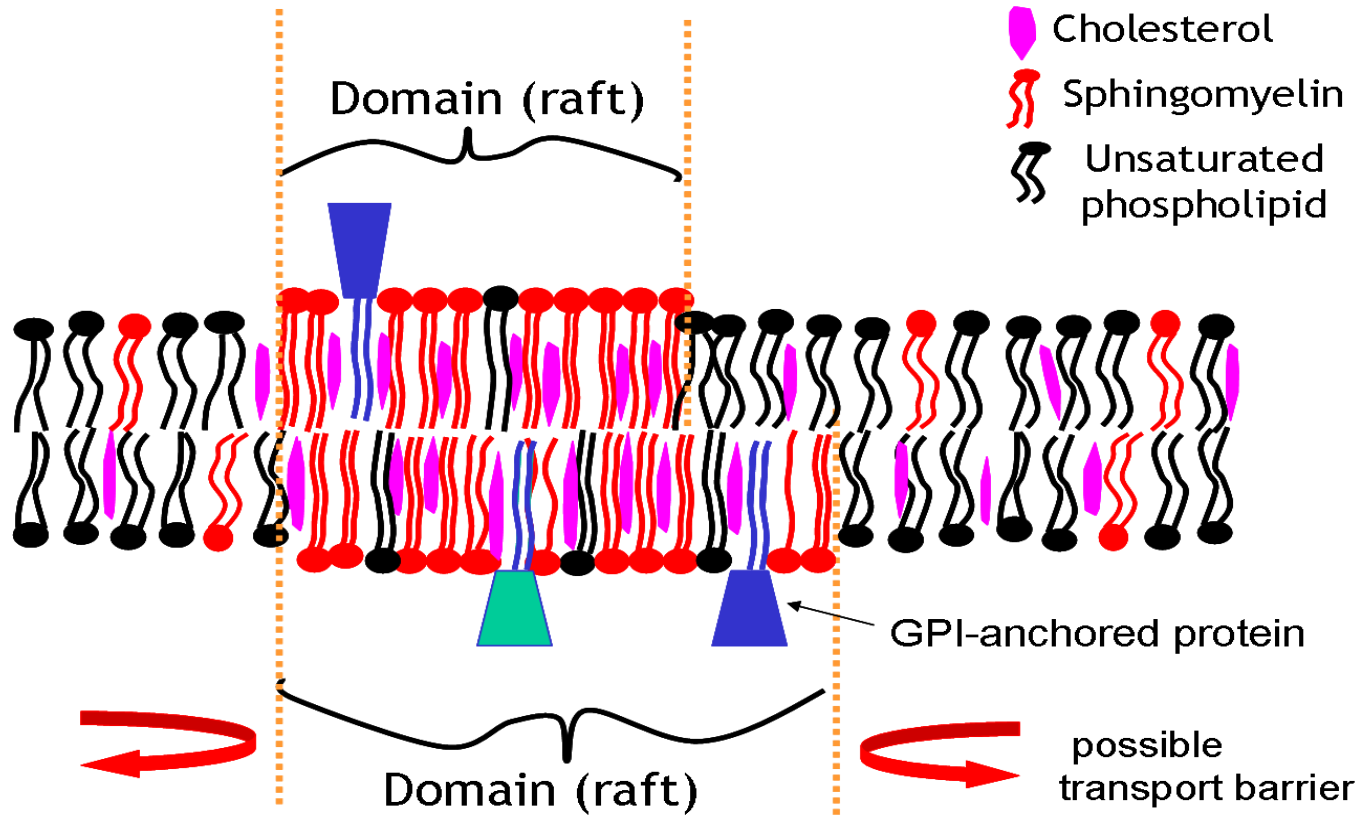

Preparation of lipid multibilayer stacks on solid supports

Cholesterol / DPPC / DOPC with the composition 30 / 35 / 35 mol%.

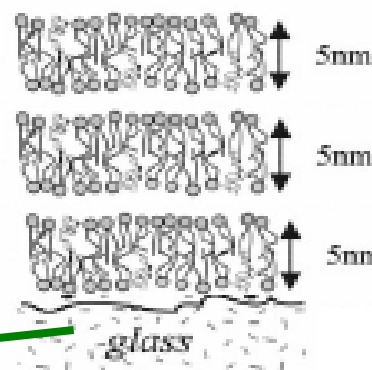
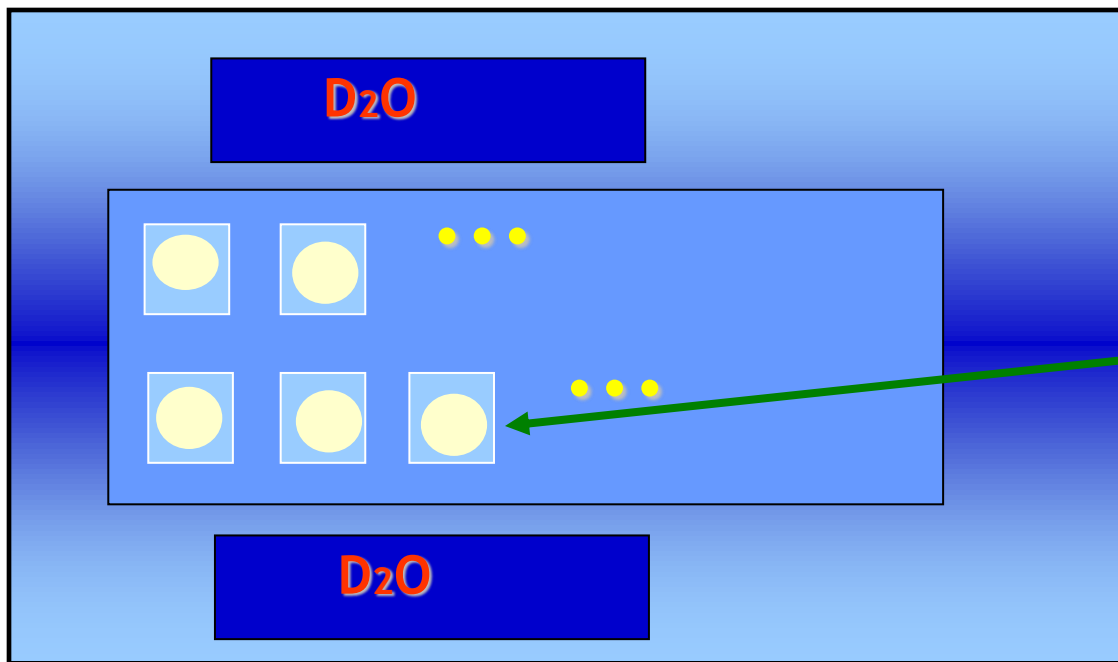

C. Dietrich *et al*
Biophys J, 2001

PFG NMR sample

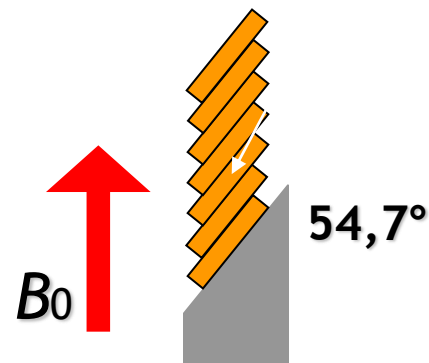

Multilayer stacks

35% DOPC (unsaturated), 35% DPPC (saturated), and 30% CHOL

Proton NMR spectra of the sample inside the insert

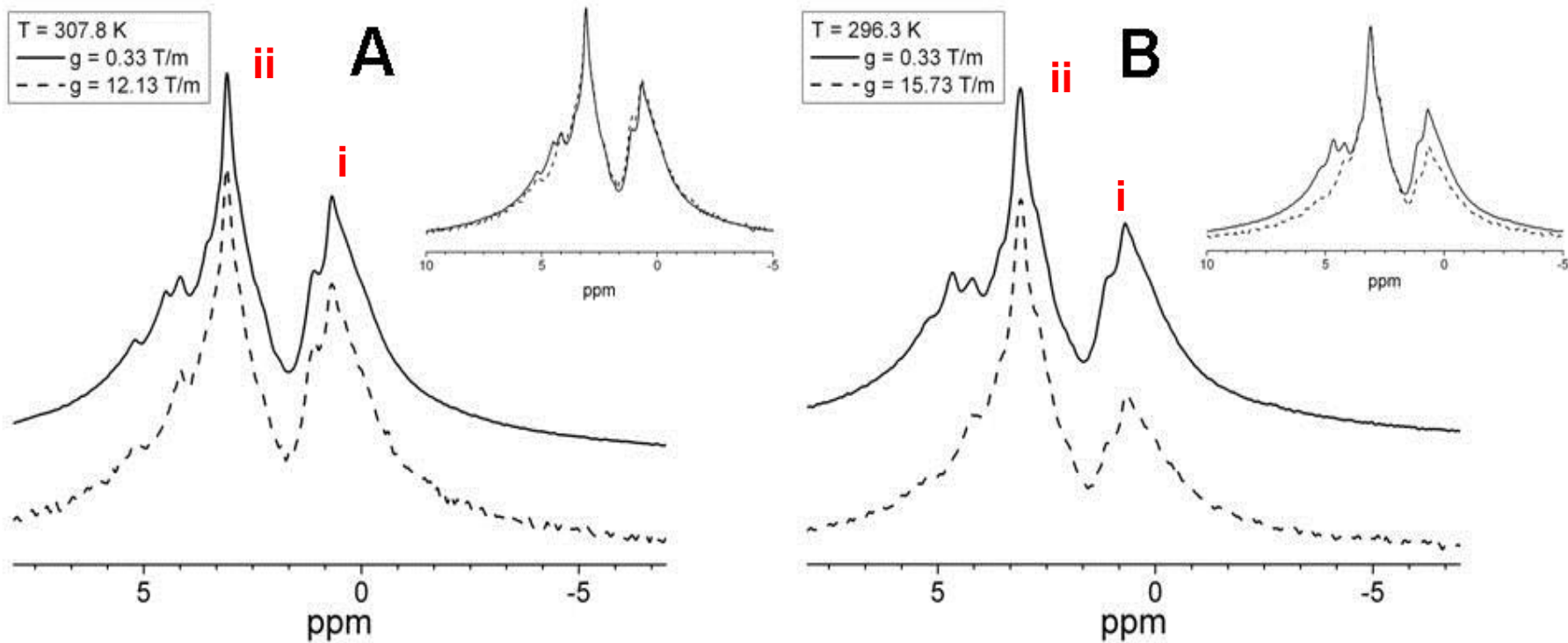

Domain-free bilayers

Bilayers with rafts

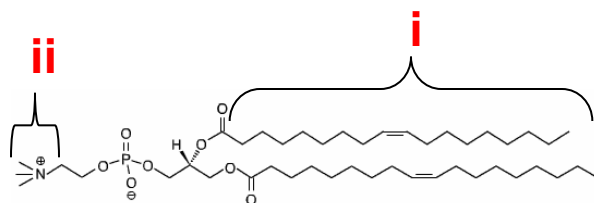

PFG NMR attenuation curves

Temperature decreases from A to E

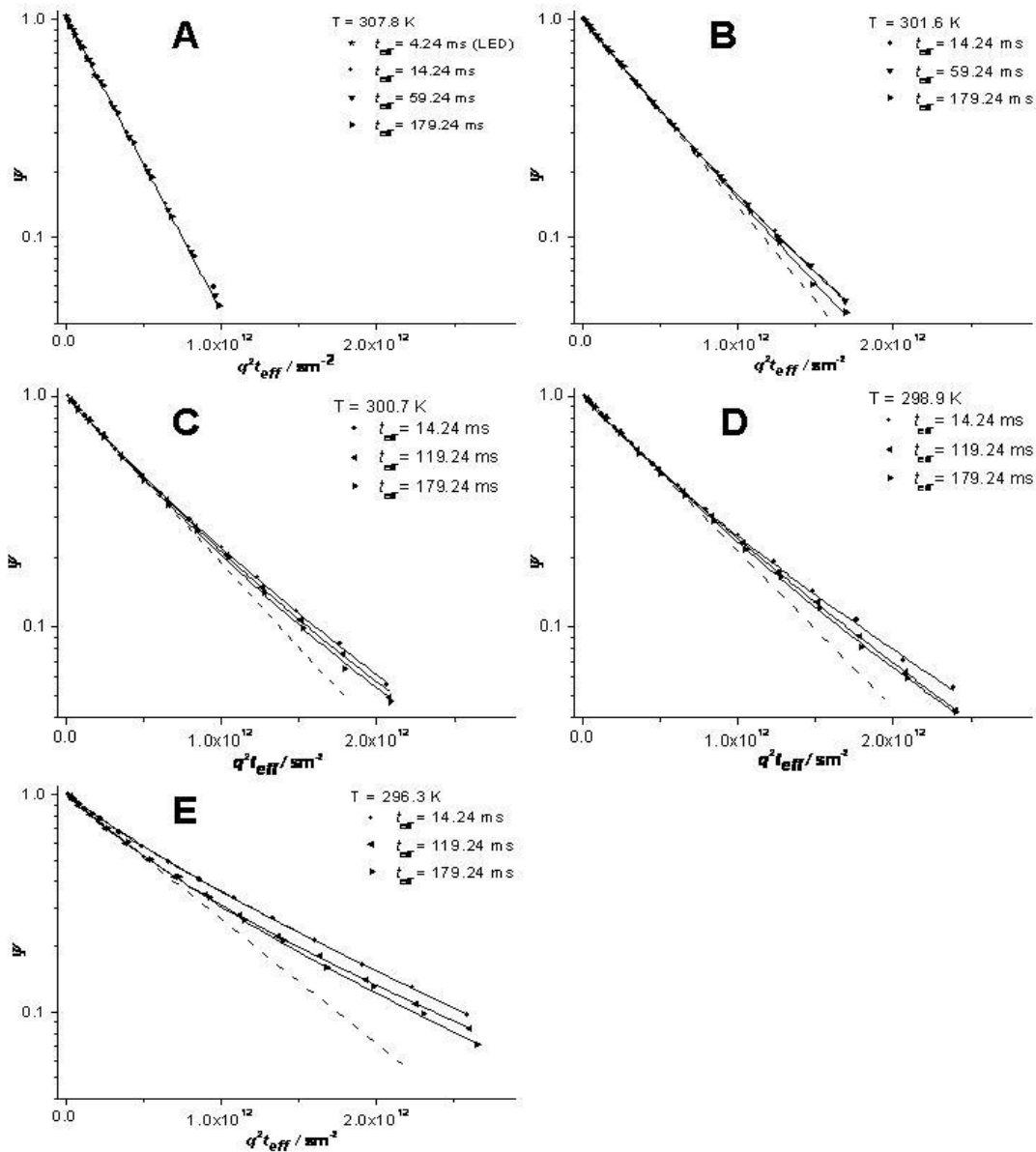

DOPC/DPPC/CHOL

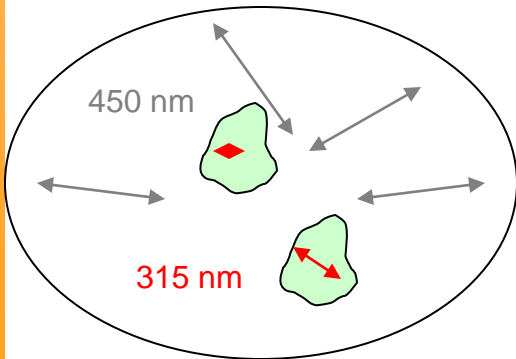
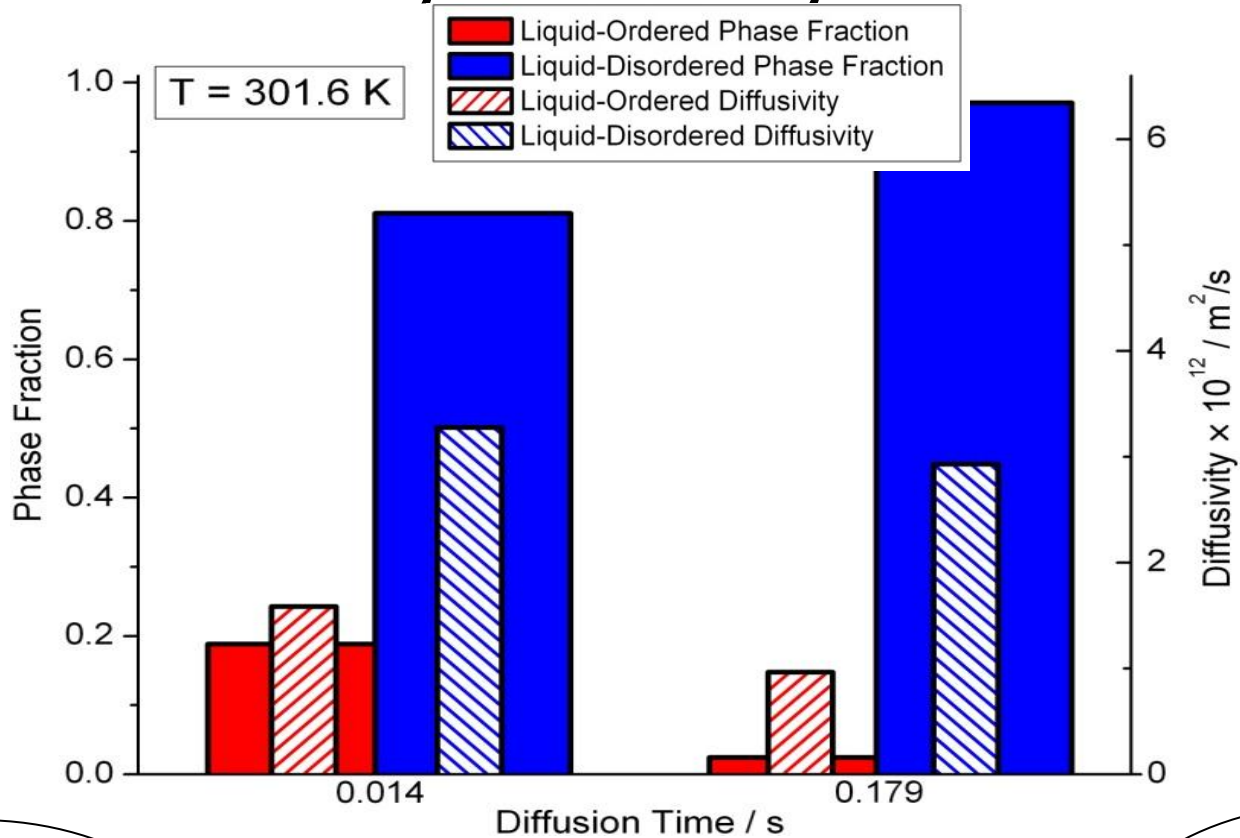

T = 301.6 K Comparison of Change in Phase Fraction and Diffusivity with Diffusion Time

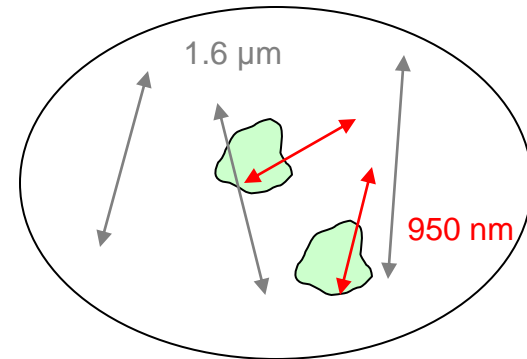

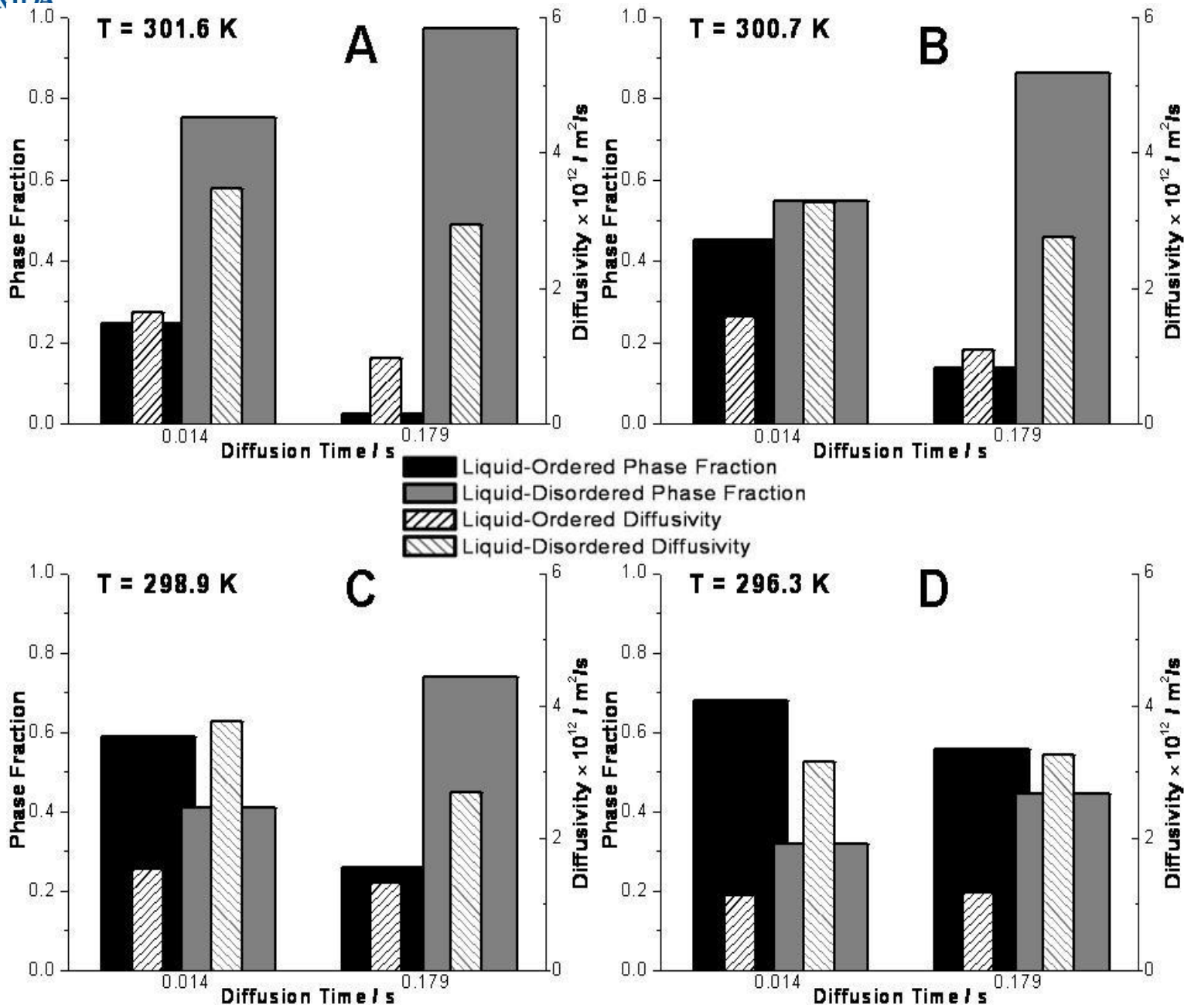

Dynamic Monte Carlo Simulations

$L = 262 \times l$ and
 $L_o = 92 \times l$
 where l is the length
 of the elementary
 diffusion step

$$1 \leq p_{lo} / p_{blo} \leq 1000$$

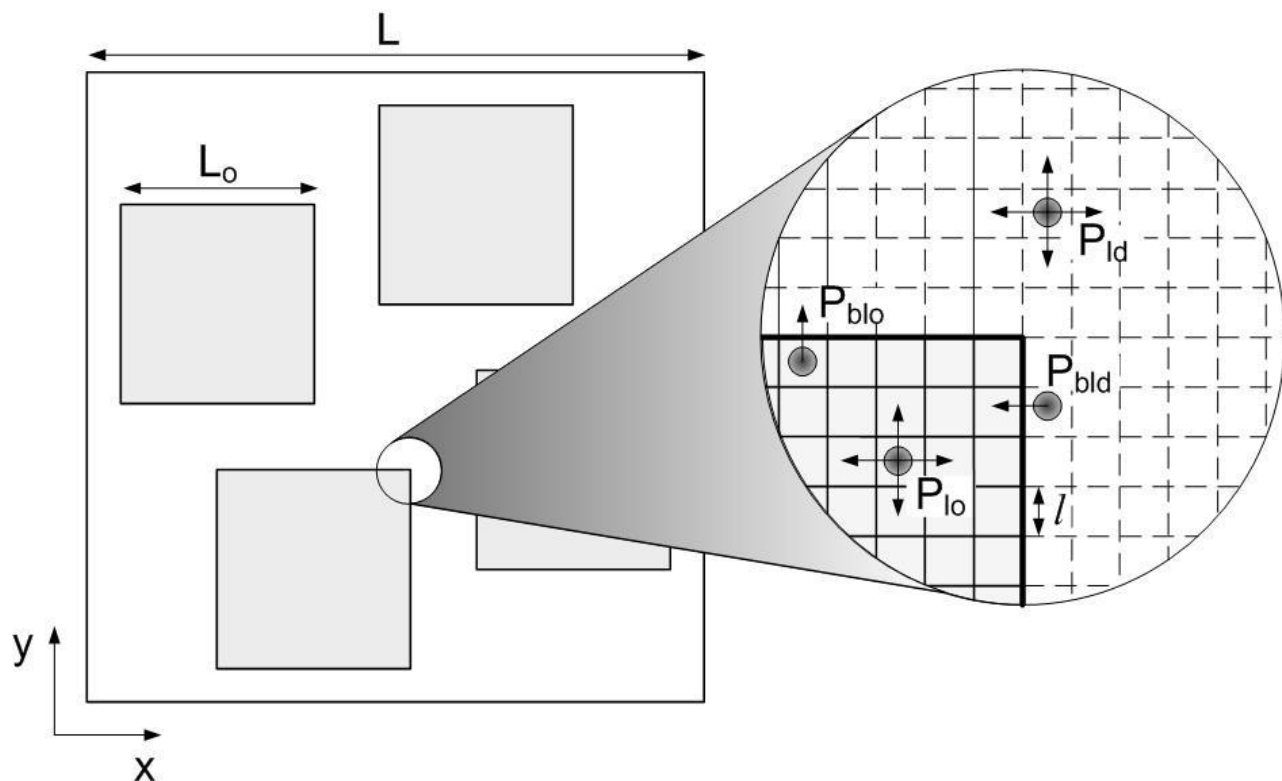

Similar type of simulations as those reported for zeolites in
 Krutyeva, M.; Kärger, J. Langmuir 2008, 24, 10474.

Krutyeva, M.; Vasenkov, S.; Kärger, J. Magnetic Resonance Imaging 2007, 25, 567.

Krutyeva, M.; Vasenkov, S.; Yang, X.; Caro, J.; Kärger, J. MMM 2007, 104, 89.

Comparison between experiment and simulations

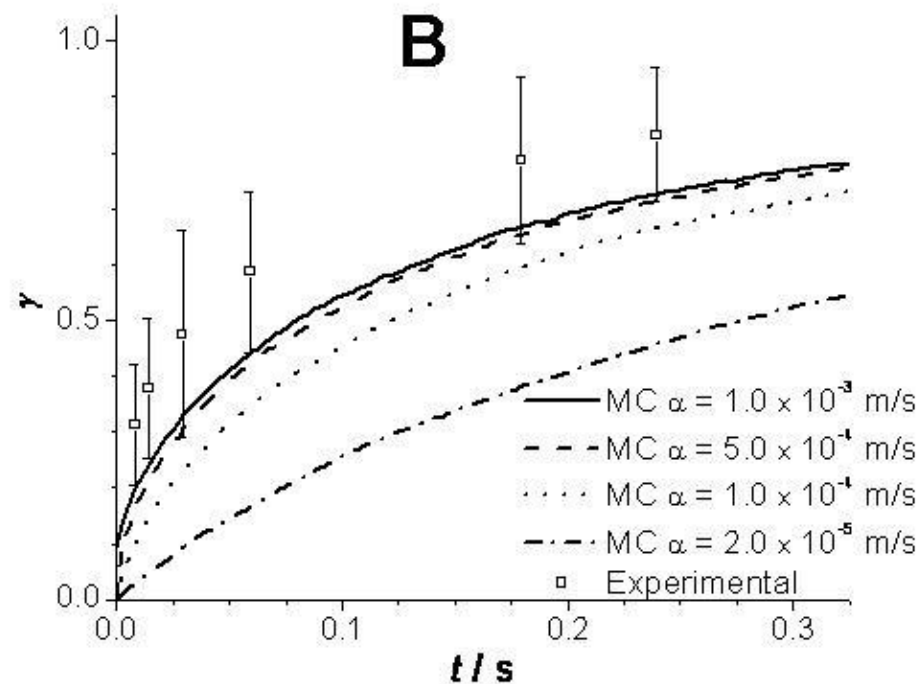
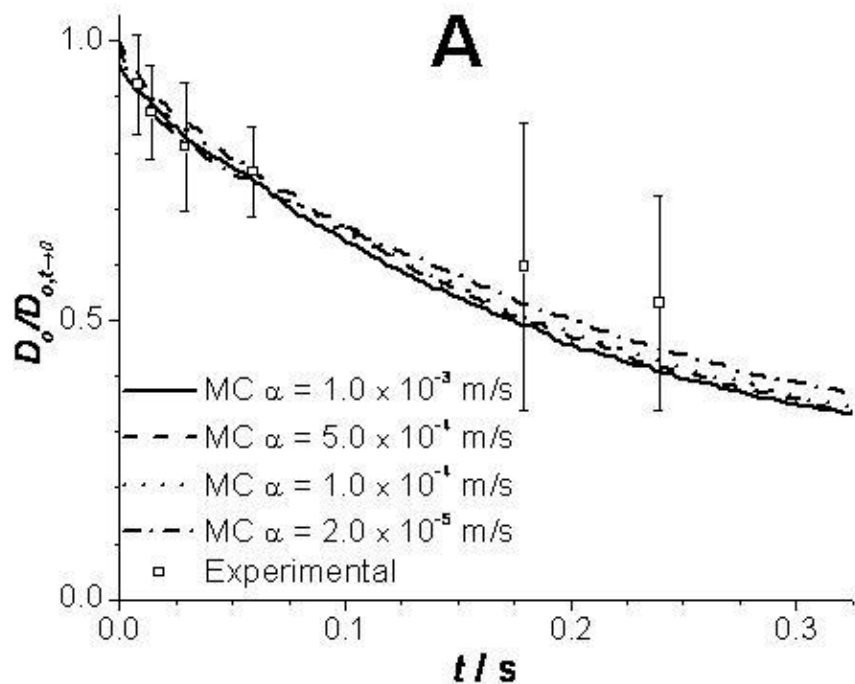

Examples of fitting experimental data (points) by the results of MC simulations (lines) for the following two dependencies: (A) time dependence of the ratio of the effective diffusivity of molecules in liquid-ordered domains to the corresponding unrestricted diffusivity in these domains, and (B) time dependence of the normalized fraction of molecules (γ) that started their trajectory inside the domains but ended their trajectory outside of domains. Experimental data was obtained at 300.7 K.

Conclusions

- Understanding influence of an absorption of small molecules on diffusion in ionic liquids
- Observation of an exchange of lipids between liquid-ordered and liquid-disordered domains in planar-supported lipid bilayers
- Quantification of the permeability of the domain boundaries in planar-supported lipid bilayers

Acknowledgements

Graduate Students

Eric Hazelbaker

Aakanksha Katihar

Amrish Menjoge

Monica Sanders

Robert Mueller

Sen-Ming Wang

Rohit Kanungo

Financial Support



Postdoctoral Scientist

Muslim Dvoyashkin

Collaborators

Prof. Edward Maginn

Prof. Joan Brennecke



T_1 NMR Relaxation

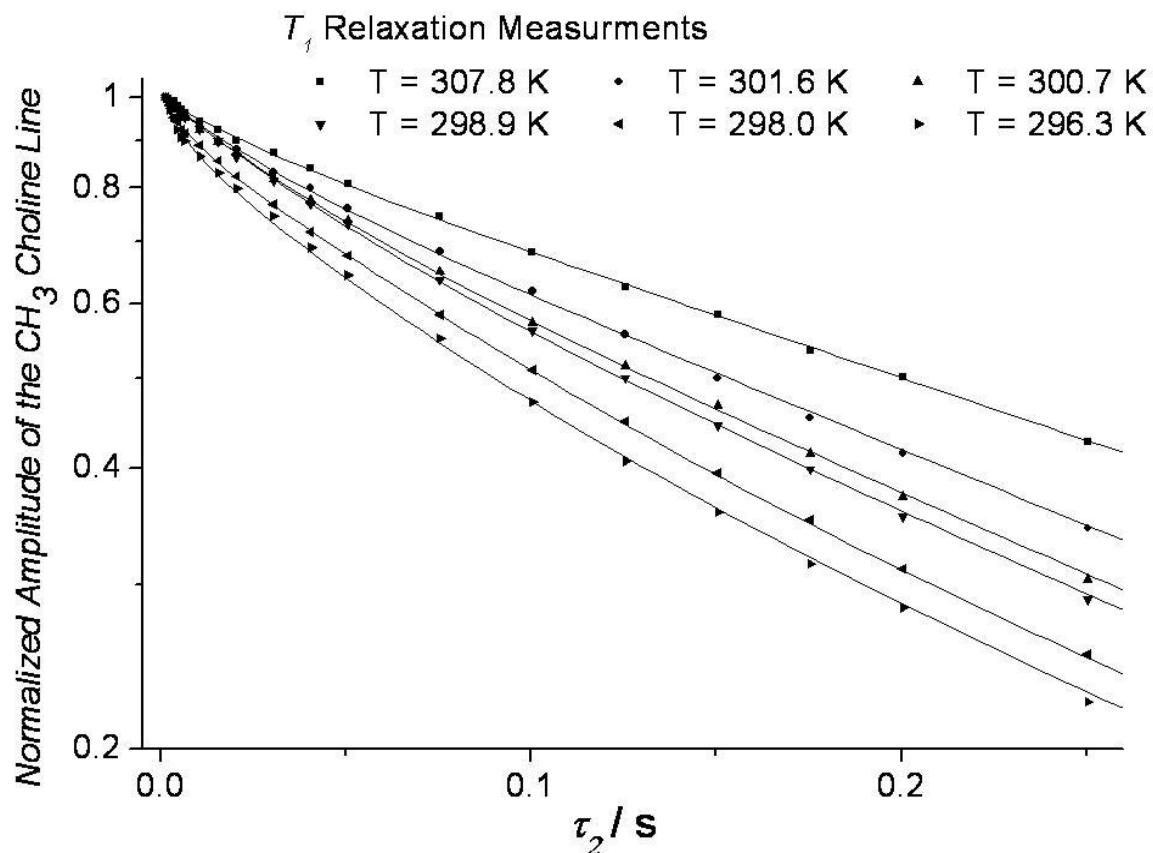

T_1 relaxation curves obtained using the STE PFG NMR sequence with $g < 1$ T/m for a range of relevant temperatures. τ_2 denotes the delay between the second and third rf pulses of the sequence

Study of the bilayer orientation by ^{31}P NMR

Cholesterol, Spingomyelin, DOPC (mol. 1:1:1) and D2O

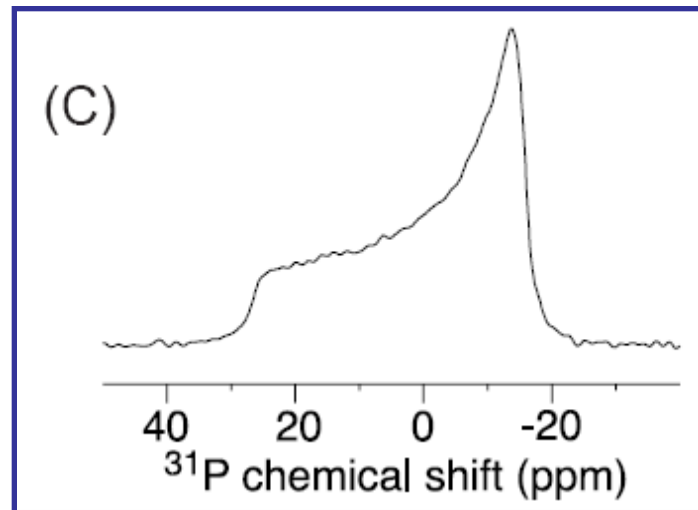
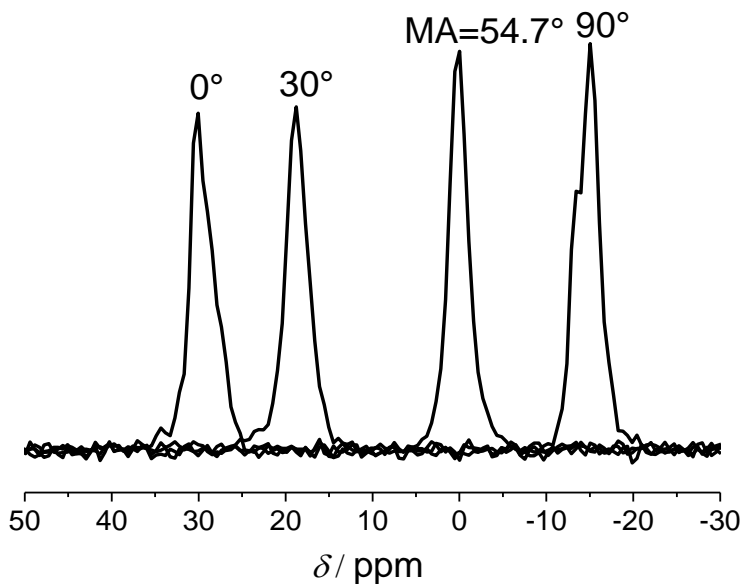

Proton-decoupled ^{31}P NMR spectra of our sample for different angles

- For randomly-oriented lipids an NMR spectrum should not depend on angle
- No such spectrum was observed
- Our estimate: at least 97% of lipids are oriented

Randomly-oriented lipids
 C. Yamaguchi *et al.*,
Biophys. J. 81 (2001) 2203-2214

Preparation of multilayer stacks on solid supports

Cholesterol, Sphingomyelin, DOPC (mol. 1:1:1) and D₂O

