

ONE P WITH TWO SPELL-OUTS: THE *ENT*-/*AUS*-ALTERNATION IN GERMAN*

Petr Biskup

Universität Leipzig
biskup@rz.uni-leipzig.de

Michael Putnam

Carson-Newman College
mputnam@cn.edu

Abstract

In this paper, we investigate German ablative *ent*-verbs and *aus*-verbs and their relation to the preposition *aus* ‘out’. We adopt a morphosyntactic Minimalist approach and argue that the alternation between German *ent*- and *aus*-verbs basically boils down to different spell-out properties of the preposition *aus*. Whereas the prefix *ent*- is a spelled out copy of the preposition *aus* moved out of PP and incorporated into the verb, the particle *aus* is a spelled out copy of the preposition *aus* that stays in PP. This analysis accounts for the different behavior of the prefix *ent*- and the particle *aus* with respect to syntactic and morphological processes. The preposition *aus* is also a spelled out copy that stays in PP. We show that the spell-out of the preposition *aus* is determined by several different factors. They include the argument structure of PP, animacy of the Ground argument, incorporation of *aus* into the verb, and the meaning of the verb.

Keywords: Preposition, Particle, Prefix, Spell-out, *ent*-verb, *aus*-verb, German

1. INTRODUCTION

In this paper, we deal with ablative prefix/particle/preposition-verb constructions in German. Specifically, we are interested in *ent*-verbs like the intransitive *entsteigen* ‘to get out’ and the transitive *entnehmen* ‘to take from’, which we call *prefixed verbs* because the P element *ent*- cannot be separated from its verb. We are also interested in *aus*-verbs such as the intransitive *aussteigen* ‘to get out’ and the transitive *ausnehmen* ‘to take from’, which we call *particle verbs*

* The authors’ names appear in alphabetic order and represent an equal effort on their respective parts. We would like to thank the following people for their helpful comments and suggestions: Fabian Heck, Gereon Müller; from the Roots workshop held at Universität Stuttgart (June 9-13, 2009): Florian Schäfer, Winfried Lechner, Artemis Alexiadou, Elena Anagnostopoulou, David Embick; and for those who provided data judgments: Marcel Guhl, Matthias Irmer, Antje Lahne, Hagen Pitsch, Olav Müller-Reichau. Special thanks go to Andrew McIntyre and Florian Schäfer for their very insightful comments on an earlier draft of this paper. The usual disclaimers apply.

because the P element *aus-* can be separated from the verb by the prefixes *zu-* and *ge-*. Finally, we are interested in the relation between the preposition *aus* and the prefixed *ent-*verbs and the particle *aus-*verbs.

Our goal is to show that there is a syntactic relation between the prefix *ent-*, the particle *aus* and the preposition *aus*. This is not very surprising given previous research by Stiebels. In her influential work (1996, 110 ff.), she shows that there is a relation between *aus*PP and the prefix *ent-* in ablative *ent-*verbs. What is new, however, is that we argue that the prefix and the particle are, in fact, just different copies of the preposition *aus*. The point is that the preposition *aus* incorporated into the verb is spelled out as *ent-*. In contrast, if the preposition stays in PP, it is spelled out as *aus* and then depending on its syntactic context, it appears either as the particle *aus* or as the preposition *aus*. We demonstrate this through a Minimalist morphosyntactic model where the spell-out of the preposition *aus* is determined by several different factors. In particular, the factors relevant to whether the preposition *aus* surfaces as a prefix, particle or preposition are the meaning of the verb, the argument structure of PP, (in)animacy of the Ground argument and (non-)incorporation of *aus* into the verb.

The paper is organized as follows. In section 2, we introduce data that we will concern ourselves with in this study. In section 3, we introduce the background of our analysis and argue that the prefix *ent-* is identical to the preposition *aus*. Then, we will discuss the argument structure of transitive and intransitive prepositional phrases. In section 4, we present our analysis of particular types of *ent-*verbs and *aus-*verbs. Here we also discuss case and different types of argument structure of *aus*PP. We will also discuss different factors relevant to the spell-out of the preposition *aus*. Finally, we focus on the boundedness effect of the Tense-Feature on the preposition *aus*. In section 5, we summarize the findings of this article.

2. THE RELEVANT DATA

In this section, we introduce the core data we analyze in this paper. Example (1a), with the intransitive motion verb *steigen* ‘to climb’, shows that the verb cannot co-occur with the dative argument. However, as shown in example (1b), taken from Stiebels (1996, 110), the prefix *ent-* added to the verb licenses the dative argument. Example (1c) then shows that the preposition *aus* licenses the dative argument as well.

- (1) a. * *Sie steigt dem Auto.*
she climbs the._{DAT} car
- b. *Sie ent-steigt dem Auto.*
she ent-climbs the._{DAT} car
'She gets out of the car.'
- c. *Sie steigt aus dem Auto.*
she climbs out the._{DAT} car
'She gets out of the car.'

The following sentences in (2) contain the transitive verb *nehmen* 'to take' and the preposition or particle *aus* show that if the bare verb co-occurs with the whole *aus*PP (i.e., the preposition *aus* and its both arguments – called the Figure (locatum) and the Ground (relatum) - are present in the sentence, for more on this see below), then the sentence is grammatical; consider (2a). In contrast, when the whole *aus*PP co-occurs with the particle verb *ausnehmen* 'to take out', the sentence is ungrammatical, as shown in example (2b). When the particle verb co-occurs only with the Ground argument, then the sentence is grammatical, as demonstrated in example (2c).

- (2) a. *Er nahm die Innereien aus dem Fisch.*
he took the._{ACC} guts out the._{DAT} fish
'He took the guts out of the fish.'
- b. * *Er nahm die Innereien aus dem Fisch aus.*
he took the._{ACC} guts out the._{DAT} fish out
- c. *Er nahm den Fisch aus.*
he took the._{ACC} fish out
'He took the guts out of the fish.'

Now, let us turn to the prefixed verb *entnehmen* 'to take from'. Example (3a) demonstrates that a sentence containing the prefixed verb with the dative Ground argument and the accusative Figure argument is grammatical. In contrast, a sentence with the prefixed verb and the whole PP is

ungrammatical, as illustrated in (3b). What example (3c) shows is that when the sentence contains the prefixed verb and the Ground argument, then it is also ungrammatical.¹

- (3) a. *Er ent-nahm dem Fisch die Innereien.*
he ent-took the._{DAT} fish the._{ACC} guts
'He took the guts out of the fish.'
- b. **Er ent-nahm die Innereien aus dem Fisch.*
he ent-took the._{ACC} guts out the._{DAT} fish
- c. **Er ent-nahm dem Fisch.*
he ent-took the._{DAT} fish

3. STRUCTURE OF PARTICLE VERBS (IN GERMAN AND BEYOND)

Before starting our analysis, let us say a few words about our background assumptions regarding the hierarchical structure of particle and prefixed verbs. We follow Lüdeling (2001) in that particle verb constructions cannot be treated as a unified class since they do not behave uniformly. Nonetheless, work by Wunderlich (1987), Stiebels & Wunderlich (1994) and Stiebels (1996, 1998), Kluge (2002), have shown that most verbal prefixes, e.g. *ver-*, *be-*, *er-*, are historically derived from prepositions and have cognates (that exist in complementary distribution) with particles contained in particle verb constructions, like e.g. *für-*, *bei-*.

In recent decades, many authors have investigated particles and prefixes in different languages and have argued that they belong to the unified category P, see Jackendoff (1973), Emonds (1985), den Dikken (1995), Zeller (2001), Matushansky (2002), Gehrke (2008), among others.

Recently, Biskup (2009, to appear) proposes that Russian and Czech prefixes and prepositions are identical elements (Ps) and that a homophonous preposition and verbal prefix occurring in one sentence can be two copies of one P element. He proposes that cases generally – i.e. also prepositional cases - are unvalued Tense-Features on the head D and that prepositions

¹ It is empirically necessary to distinguish between these ablative *ent-*verbs and other types of *ent-*verbs such as the inchoative *entbrennen* and *entflammen* (both meaning something roughly 'to set into flames') or *ent-*verbs like *entspannen* 'to relax' and *enthemmen* 'to disinhibit', in which the prefix *ent-* seems to work as a negative operator. In this article, we restrict ourselves solely to the ablative *ent-*verbs.

bear unvalued ϕ -Features and a valued Tense-Feature.² This is an extension of Pesetsky & Torrego's (2004, 2006) proposal, who suggest that structural case is an unvalued Tense-Feature on D that is valued by the head T and T₀ (Asp) and that prepositions bear a valued Tense-Feature. Biskup's analysis has the advantage that all cases are treated uniformly as an instance of the operation Agree (cf. Chomsky 2000 *et seq.*) between Tense-Features and ϕ -Features of the Probe and Goal. Another advantage is that the presence of the valued Tense-Feature on prepositions can explain the relation between PP (the prepositional case and the lexical aspect), the morphological aspect and the perfective structural accusative. Since the value of the prepositional Tense-Feature is bounded, it is responsible for different definiteness effects: perfectivity, which can be treated as boundedness or definiteness of the reference time, islandhood of PPs (it is known that islandhood is related to definiteness) and islandhood of the perfective structural accusative.

To be more concrete, let us look at how the proposal works in a particular derivation. Consider the Czech sentence (4a) and the relevant part of its derivation in (4d).

- (4) a. *Pavel do-lil vodu do sklenice.*
Pavel_{.NOM} to-poured water_{.ACC} to glass_{.GEN}
'Pavel topped off the glass with water.'
- b. *Pavel lil vodu do sklenice.*
Pavel_{.NOM} poured water_{.ACC} to glass_{.GEN}
'Pavel was pouring water into the glass.'
- c. **Lil Pavel do- vodu do sklenice?*
poured Pavel_{.NOM} to water_{.ACC} to glass_{.GEN}

² Support for this comes from languages with prepositional agreement like Abaza, Irish, Jacaltec, Welsh (see Baker 2008, Brennan 2008) and from languages with tensed prepositions as in Titan or Māori (Bowerman & Aygen-Tosun 2000, Harlow 2007). Note also that PPs can have a temporal interpretation.

d.

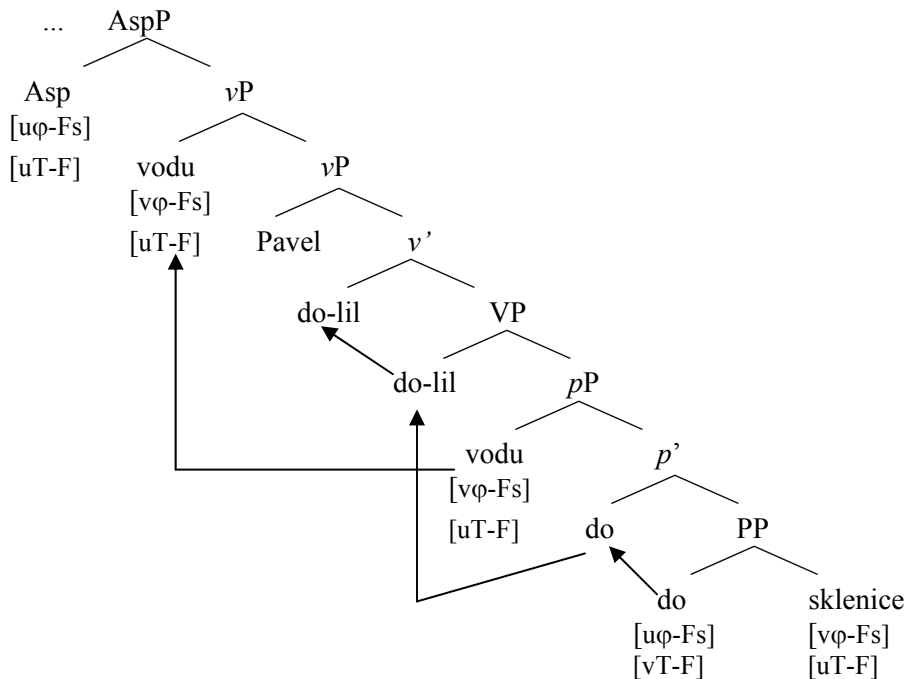

The preposition *do* ‘to’, which bears a valued Tense-Feature and unvalued ϕ -Features, is merged with DP *sklenice* ‘glass’, which bears an unvalued Tense-Feature and valued ϕ -Features. *Do* and *sklenice* agree and the unvalued ϕ -Features of the preposition *do* are valued by the valued ϕ -Features of *sklenice* and the unvalued Tense-Feature of *sklenice* is valued by the valued Tense-feature of *do*, which results in the genitive case on *sklenice*. Then, the little prepositional head *p* is merged and *do* moves to *p*. DP *vodu* ‘water’ is merged as a specifier of *p*, and it is later interpreted as the Figure argument and located with respect to *sklenice*, which is interpreted as the Ground argument.

The root *li* ‘to pour’ is then merged as the big verbal head. It could also be labeled as Root, project RootP and become a verb by being c-commanded by the little verbal head *v*, in line with the Distributed Morphology (DM) framework, but nothing hinges on this assertion. What is important here is just that the narrow syntax can manipulate particular morphemes. Since we make the standard assumption that syntactic objects are triples of features - phonological, semantic and formal - see e.g. Chomsky (1995a, 394), this means that the narrow syntax works with formal features of particular morphemes.

In the next step, the preposition *do* incorporates into the root *li* and the complex head *do-li* then incorporates into the head *v*, which has been merged with VP. The past participle ending *-l*

is merged higher in the derivation but for ease of exposition we put syntactic objects into trees fully inflected in this article. The argument *Pavel* is merged as a specifier of *v* and is interpreted as agent of the complex event at the semantic interface. The specifier of *pP vodu* moves to the edge of *vP*, i.e. given the Extension Condition, to the outer specifier of *vP*. Next, the aspectual head selects *vP* and since it bears an unvalued Tense-Feature, the incorporated preposition *do*, which bears the Tense-Feature with the value bounded, values its Tense-Feature as perfective.³ Given the lexicosemantic properties of the preposition *do*, the perfective reference time corresponds to the transition between the process subevent and the result subevent, which means that the Figure argument *water* is contained in the *glass*. The aspectual head also bears unvalued ϕ -Features, which probe and find the valued ϕ -Features on *vodu*. Then the operation Agree takes place and the unvalued ϕ -Features on the aspectual head are valued by the valued ϕ -Features on *vodu* and the unvalued Tense-Feature on *vodu* is valued by the Tense-Feature on the aspectual head (which has been valued by *do*) as perfective structural accusative, which has certain consequences for possibility of extraction, as we will see in section 4.3.

When the preposition *do* stays in the head *p* and does not incorporate into the verb, the unvalued Tense-Feature on the aspectual head is valued as imperfective by the verb. Consequently, there is no result state, as shown by example (4b). The unvalued Tense-Feature on the direct object *vodu* is then valued by the Tense-Feature on the aspectual head as imperfective structural accusative.

Example (4c) then demonstrates that the incorporated preposition *do* cannot be stranded by the moved verb *lil* in the question formation. Such stranding data are excluded by the standard assumption that excorporation of a head is not possible (see e.g. Baker 1988, Roberts 2001). German data may be accounted for in the same way. Since the prefix *ent-* is in fact the preposition *aus* incorporated into the verb, as we will argue in the following sections, then due to

³ A similar effect can be observed in the case of the incorporated preposition *aus* in German. The following example demonstrates that the incorporated preposition brings about telicity. (ia) shows that the unprefixated predicate *lief* ‘ran’ is compatible with the *for*-adverbial *zwei Stunden* ‘two hours’, but not with the *in*-adverbial *in zwei Stunden*. However, when *aus* incorporates into the verb and surfaces as the prefix *ent-*, the predicate is compatible only with the *in*-adverbial, which means that the prefixed predicate is telic; consider (ib).

- (i) a. Er lief zwei Stunden / * in zwei Stunden.
 he walked two hours in two hours
 ‘He walked two hours/*in two hours.’
 b. Er ent-lief * zwei Stunden / in zwei Stunden.
 he ent-walked two hours in two hours
 ‘He escaped *two hours/in two hours.’

the ban on excorporation, the verb moving to the first/second position cannot strand its incorporated prefix in a lower position.

An approach that treats morphological processes as part of the syntactic derivation has the advantage that it can straightforwardly account for the coincidence of morphological and syntactic separability in the case of particles and the coincidence of morphological and syntactic inseparability in the case of prefixes. Recall that German particle verbs can be separated both by syntactic operations (e.g. verb-second or verb-first) and by morphological operations (e.g. participle formation, infinitive formation) and that prefixed verbs can be separated neither by syntactic nor by morphological operations. This consistent behavior supports the view that the operations belong to one component of the grammar. Since some of the operations, e.g. the verb-second operation, are necessarily syntactic, the relevant component must be the syntax. Consequently, the syntactic incorporation analysis of the prefix *ent-* and the non-incorporation analysis of the particle *aus* can account for why the prefix, in contrast to the particle, cannot be separated from the verb later in the derivation by another morpheme.

Since from the conceptual point of view one generative component is better than two generative components, we pursue the non-lexicalist approach to preverbs (prefixes and particles) in this article. In addition, if prefixed and particle verbs are derived by means of semantic operations in the lexicon, as in Stiebels (1996), then there are in fact two semantic components in the grammar model, which is again from the conceptual point of view not desirable. In this respect, cf. Lüdeling (2001, chap. 2) arguing that there is no need to assume such semantic lexical processes. The syntax provides a compositional mechanism and the resultant (sub)structures are appropriately interpreted at the semantic interface.

3.1 Prefix *ent* = preposition *aus*

In this section, we argue that the prefix *ent-* is in fact the preposition *aus* and present several arguments supporting this claim. Since our analysis is of the synchronic type, it does not play a role that the prefix and the preposition are not etymologically related (cf. Baker 1988, chap. 5).

Our first argument is based on the fact that both the preposition *aus* and the prefix *ent-* license the dative case, as demonstrated in example (1b,c).⁴ Secondly, both *aus* and *ent-* also

⁴ There are also other prepositions and particles licensing dative, e.g. *bei* ‘at’, which may suggest that they could be analyzed in a way parallel to *aus/ent-*.

license the same interpretation of the appropriate argument, concretely the Ground (relatum) interpretation, as shown in (1b,c). The next argument is based on the fact that both the *ent*-verbs and verbs with *ausPP* bring about telic (bounded) interpretation; they bring about a transition from subevent A to subevent B, more concretely, the source meaning. *Ent*- and *aus* are transitive predicates and the first argument (the Figure) is located with respect to the second argument (the Ground). In subevent A, the Figure argument is placed ‘in’ or ‘at’ the Ground argument and in subevent B, which is contiguous with subevent A, it does not hold that the Figure is placed ‘in’ or ‘at’ the Ground.⁵ The fourth argument comes from Stiebels (1996, 110), who maintains that sentences with *ent*-verbs can be paraphrased by sentences with verbs + *ausPP*. The final argument is based on extraction data like (5), which demonstrate that both *aus* and *ent*- block extraction. Example (5a) shows the base unmarked sentence. Sentence (5b) demonstrates that extraction out of *ausPP* is ungrammatical. Example (5c) then shows that extraction of PP *worüber* ‘about what’ out of the accusative direct object is just slightly marked when it happens in a sentence with the unprefixed predicate *nahm* ‘took’. However, when *worüber* is extracted out of the accusative object in a sentence with the predicate *nahm* prefixed by *ent*-, the extraction is ungrammatical, as shown by example (5d).⁶

- (5) a. *Er nahm ein Buch über Autos aus dem Regal.*
 he took a.ACC book about cars out the.DAT shelf
 ‘He took a book about cars from the shelf.’
- b. **Welchem Regal₁ nahm er ein Buch über Autos [PP aus t₁]?*
 which bookshelf took he a.ACC book about cars out?

⁵ In certain cases, the locational relation expressed by *ent*- seems to be more abstract, as shown in example (i) by Andrew McIntyre (p.c.). Example (ia) means roughly: not to be within striking-distance (i.e. to get out of the neighborhood region) of the monster anymore. Example (ib) means that the chain saw is not in the possession of the Ground argument (*ihm*) anymore. This can also be treated as a locational relation since there is a close relation between location and possession (see e.g. Wunderlich in press).

- (i) a. *dem Monster ent-fliehen*
 the.DAT monster ent-escape
 ‘to escape the monster’
- b. *Ein Mann ent-riss ihm die Kettensäge.*
 a man ent-wrenched him.DAT the.ACC chain saw
 ‘A man wrenched the chain saw from him.’

⁶ According to our informants (participants of the colloquium ‘Neuere Arbeiten zur Grammatiktheorie’, Universität Leipzig, summer semester 2009), the preposition stranding in (5b) is a little bit worse than the extraction in (5d). Sentence (5d) is also bad when *dem Regal* ‘the bookshelf’ follows *ein Buch* ‘a book’.

- c. ? [*Worüber*]₁ *nahm er [ein Buch t₁] aus dem Regal?*
 about what took he a.ACC book out the.DAT shelf
 ‘About what did he take a book from the shelf?’
- d. ?* [*Worüber*]₁ *ent-nahm er dem Regal [ein Buch t₁]?*
 about what ent-took he the.DAT shelf a.ACC book

Having established the identity of the prefix *ent-* and the preposition *aus*, we can now turn to the argument structure of the preposition itself.⁷ In the next section, we will propose the argument structure for transitive and intransitive *aus*PPs.

3.2 The argument structure of *pP*

This section is concerned with the argument structure of the *aus* prepositional phrase. In this respect, we build on Talmy (1975, *et seq.*), Svenonius (2003, 2007) and Biskup (2009, to appear). As already discussed in the previous section, the preposition *aus* is a two-place predicate. Talmy (1975, *et seq.*) calls the two arguments *Figure* and *Ground*. The Figure argument (locatum) is the entity that is located or characterized with respect to the Ground argument (the reference object, relatum).

Svenonius (2003, 2007) builds on Talmy and splits prepositional phrases into PP and *pP*, analogously to verbal projections, because, as in the case of verbal projections, there is an asymmetry in behavior of the external argument (the Figure) and the internal argument (the Ground). Thus, the head *p* introduces the Figure argument and the head P introduces the Ground argument. He also argues that *p*PPs can be transitive as well as intransitive (both unergative and unaccusative).

⁷ One might object that *ent-* cannot be *aus* because there are cases of non-equivalences like (i). However, it is known that phrasal constructions can be lexicalized. Note that although cases like (ib) are lexicalized, it does not mean that such cases must be derived in a presyntactic lexicon.

- (i) a. Andrew kam aus Leipzig.
 Andrew came out Leipzig
 ‘Andrew came from Leipzig.’
 b. Andrew ent-kam Leipzig.
 Andrew ent-came Leipzig
 ‘Andrew got away from Leipzig.’

As already discussed at the beginning of section 3, Biskup (2009, to appear) proposes that case on the prepositional complement is a reflection of the operation Agree between Tense-Features and ϕ -Features of the preposition and the prepositional complement.

Taken together, we receive the following structure for the transitive and unergative *pP* (we analyze unergative *pPs* as a covert transitive *pP*, analogously to unergative *vPs*, see, for example, Haumann (2002) and references therein for the proposal that the internal argument of overtly intransitive prepositions can be analyzed as *pro*).⁸

(6) Transitive (unergative) *pP*

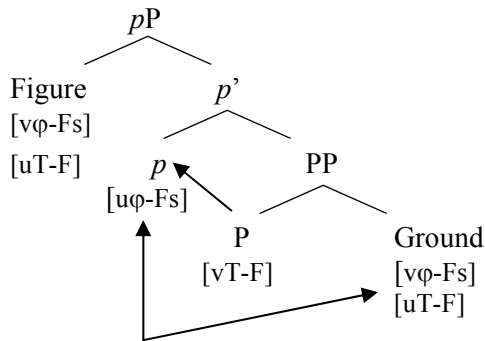

We assume that the valued Tense-Feature is an inherent property of the head *P*. In the first step, the head *P* merges with its complement DP (the *Ground*), which bears the unvalued Tense-Feature and valued ϕ -Features, as demonstrated in (6). Then, the head *p* - which is non-defective in the case of transitive and unergative *pPs*, bearing unvalued ϕ -Features - merges with *PP*. In the next step, the head *P* incorporates into *p*; we assume that this movement step is obligatory, in parallel to the standardly assumed obligatory V-to-*v* movement. The unvalued ϕ -Features on the head *p* probe and find the *Ground* with valued ϕ -Features, which results in the Agree operation between the Tense-Feature and ϕ -Features of the complex head *P+p* and the unvalued Tense-Feature and valued ϕ -Features of the *Ground* argument. Since cases are generally an unvalued Tense-Feature on the head *D*, as proposed above, this means that the *Ground* argument receives a case. In the final step, the external argument of the preposition (the *Figure*) with its unvalued Tense-Feature and valued ϕ -Features is merged with *p'*. For unaccusative *pPs*, we propose the following structure.

⁸ From now on, for prepositional phrases, we use the abbreviation *pP* instead of *PP*.

(7) Unaccusative *pP*

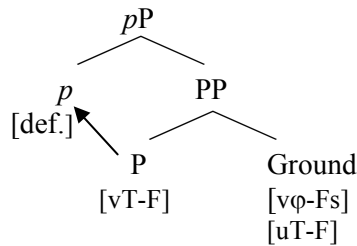

As in the case of transitive (unergative) *pPs*, the head *P* bears a valued Tense-Feature and merges with the internal argument (the Ground), which bears the unvalued Tense-Feature and valued ϕ -Features. In the next step, the head *p* - which is defective, hence does not bear ϕ -Features - merges with *PP*. Then, the head *P* incorporates into *p*. Since the head *p* does not bear ϕ -Features, there is no Agree relation between *P+p* and the Ground argument and given the Case Filter (originally formulated in Chomsky 1981), the Ground must receive case higher in the structure. Since the head *p* is defective, it does not introduce a Figure argument, thereby we arrive at a *pP* type of Burzio's generalization.

It is important to note that we make an assumption that a Tense-Feature can participate in the operation Agree only if it parasitizes onto ϕ -Features-Agree or on selecting Features. This prevents the unvalued Tense-Feature on the Figure and Ground from probing. Hence, in the structure in (6) and (7), the Ground argument cannot satisfy its case requirement by probing into the head *P*. In order to derive the different behavior of transitive (unergative) and unaccusative *pPs*, case of the Ground argument must depend on the presence/absence of ϕ -Features on the non-defective/defective head *p*. With respect to the Figure argument in transitive and unergative *pPs*, this assumption prevents the unvalued Tense-Feature of the Figure from probing into its sister and finding the valued Tense-Feature of the head *P*. This has the welcome consequence that the Figure argument must receive case somewhere higher in the structure. Having said this, we can now turn to the alternation between *ent*-verbs and *aus*-verbs and show how our proposal works in particular *aus*-derivations.

4. ENT-/AUS-ALTERNATION VERBS

In this section, we discuss the alternation between *ent*-verbs and *aus*-verbs. We begin our discussion with case and different types of argument structure of *auspP*. Afterwards, we will

continue with factors relevant to the spell-out of the preposition *aus*. Finally, we will focus on the boundedness effect of the Tense-Feature present on the preposition *aus*.

4.1 Case and argument structure of *aus*-verbs and *ent*-verbs

4.1.1 Unprefixed verbs with transitive *pP*

Let us begin our discussion with the unprefixed verb *nehmen* ‘to take’ and example (2a), repeated here for convenience as (8). We already know that when the bare verb co-occurs with the whole *auspP*, the sentence is grammatical.

- (8) *Er nahm die Innereien aus dem Fisch.*
he took the._{ACC} guts out the._{DAT} fish
‘He took the guts out of the fish.’

The derivation of the *auspP* in sentence (8) works as in (6) above. First, *aus* with its valued Tense-Feature merges with the Ground argument *dem Fisch* ‘the fish’, which bears the unvalued Tense-Feature and valued ϕ -Features, consider the relevant part of derivation shown in (9).⁹ Next, *PP* merges with the non-defective head *p*, which bears unvalued ϕ -Features, and *aus* incorporates into it. The unvalued ϕ -Features on *p* Probe and find the Ground *dem Fisch* with its valued ϕ -Features. This results in Agree between the Tense-Feature and ϕ -Features of the prepositional complex head and the unvalued Tense-Feature and valued ϕ -Features of the Ground. Given the case properties of preposition *aus*, the Tense-Feature of the Ground argument is valued as dative: *dem Fisch*. In the next step, the external argument *die Innereien* ‘the guts’ with its unvalued Tense-Feature and valued ϕ -Features is merged with *p*’ and later, at the semantic interface, it is located with respect to the Ground argument *dem Fisch*. Thus, the guts result outside the fish.

⁹ We present only parts of derivations relevant to our discussion. Thus, there are yet other syntactic processes that can change the form of the appropriate sentences, e.g. scrambling, topicalization etc.

(9)

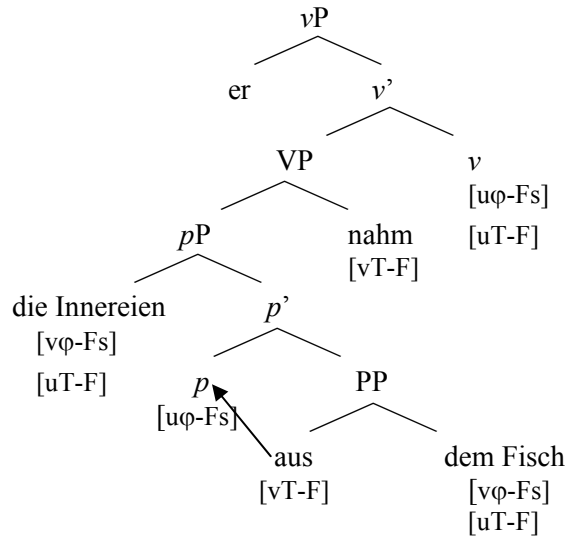

The question arises how the Figure receives its case. We assume that structural accusative is valued by the head v in German, not by the aspectual head as in the analysis of Czech in section 3. We do not assume the aspectual projection here because German does not have morphological aspect. Analogously to the aspectual head in Czech, v bears unvalued ϕ -Features and an unvalued Tense-Feature parasiting on selecting features of the head v . The unvalued Tense-Feature on the head v is valued by the valued Tense-Feature of the head V as unbounded because we follow Kratzer (2007, see also references therein) in that verbal roots have the cumulative denotation (this will become important later with respect to extraction out of accusative DPs). Then, unvalued ϕ -Features of v probe and Agree occurs between the ϕ -Features and Tense-Features of v and the Figure. As a consequence, the Figure argument gets the structural accusative: *die Innereien*.

4.1.2 Unprefixed verbs with unaccusative pP

Now, we will look at the unprefixed verb *nehmen* 'to take' with an unaccusative $auspP$. In section 2, we saw that when the verb co-occurs with the intransitively used preposition (particle) *aus* and with the direct object that is interpreted as the Ground argument (relatum), the sentence is grammatical. Consider the following example, repeated from (2c).

(10) *Er nahm den Fisch aus.*

he took the._{ACC} fish out

'He took the guts out of the fish.'

We propose that in this case the *pP* works as in the structure in (7). The head P *aus* bears a valued Tense-Feature and merges with the Ground argument bearing the unvalued Tense-Feature and valued ϕ -Features, as demonstrated in (11). Next, *PP* merges with the head *p* that is defective, i.e., it does not bear ϕ -Features and does not introduce a Figure argument; therefore only the Ground argument (relatum) is present in the sentence (in addition to the agent *er* ‘he’ merged in the specifier of *vP*). Then, *aus* incorporates into *p*. Since the head *p* is defective, the unvalued Tense-Feature on the Ground cannot be valued. In order not to violate the Case Filter, the Ground must receive case in a higher position. The next possible case assigner is the head *v* with structural accusative. Under the assumption that defective *pPs* are also phases, the Ground argument moves to the edge of *pP* to be accessible for *v*, as demonstrated in (11).

(11)

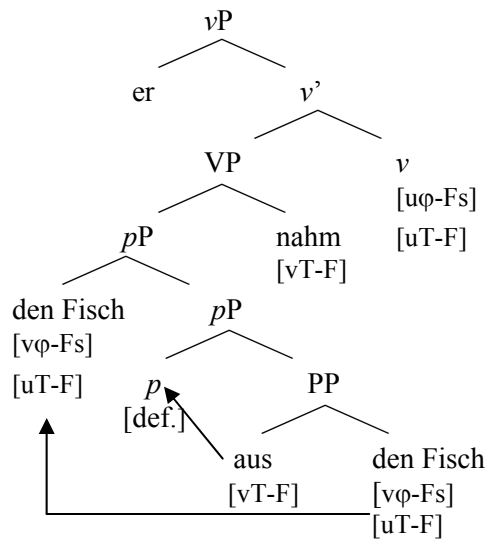

When unvalued ϕ -Features on the head *v* Probe, they find the valued ϕ -Features on the Ground, which results in the Agree operation between the ϕ -Features and Tense-Features on *v* and the Ground. Consequently, the Ground argument receives structural accusative. That the Ground receives the structural accusative is supported by the following passive example, where *der Fisch* bears nominative instead of accusative.

- (12) *Der Fisch wurde aus-ge-nommen.*
the._{NOM} fish was out-ge-taken
'The fish was gutted.'

4.1.3 *Ent*-verbs with transitive *pP*

According to Stiebels (1996, 110) the 'applied' object licensed by *ent*-verbs almost always receives dative case, as demonstrated by example (13).

- (13) *Er ent-nahm dem Fisch die Innereien.* = (3a)
he ent-took the._{DAT} fish the._{ACC} guts
'He removed the guts from the fish.'

According to our analysis proposed here, we can provide the following account for this phenomenon. Given the arguments set forward in section 3.1 that the prefix-form *ent*- corresponds to the preposition *aus*, we advanced the hypothesis that *ent*- is the incorporated (into V) form of *aus*. The derivation provided in (14) demonstrates how prefixed verbs with a transitive *pP* (as in (6)) are handled in our analysis. A crucial factor is that the P-element *aus* does not stop in *p*, but continues in the derivation until it incorporates into *v*. The complex head *aus+p* assigns dative to the applied object *Fisch* 'fish' and then continues to move through the derivation incorporating into *v*.¹⁰ Note that structural accusative is assigned to Figure by *v*.

¹⁰ The same phenomenon, i.e. cases where the verb seemingly inherits case from the incorporated preposition, can be observed in other languages as well (see e.g. Greek and Latin examples in Miller 1993).

(14)

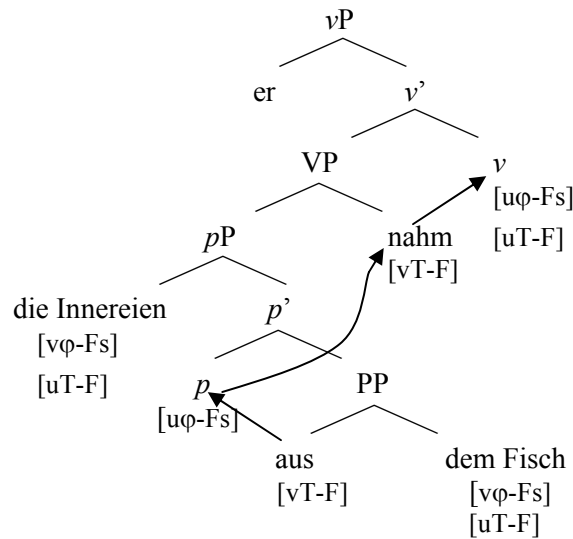

4.1.4 *ent*-verbs and intransitive *pP*

Based on the analysis provided above, the incorporated form of the P-element *aus*, that merges with V, is spelled out as *ent-* and is responsible for assigning dative case to the applied object. If this analysis is on the right track, then it is puzzling – at least from a preliminary view – why (15) is ungrammatical.

(15) * *Er ent-nahm dem Fisch.* = (3c)
 he ent-took the_{DAT} fish

From a surface perspective, it appears that the incorporated P-element *ent-* somehow fails to assign dative case to the applied object. This discrepancy is, however, merely a surface issue; what lies at the heart of the matter here is that (15) lacks a Figure argument (compare this example with example (13) above). To account for the ungrammaticality of (15) based on the analysis developed here, we are faced with two possible scenarios:

Scenario 1: If there is no Figure, *p* could be defective hence dative case cannot be assigned.

Scenario 2: The verb *entnahm* in (15) is not compatible with an unaccusative *pP*.

We can immediately see that Scenario 1 cannot be correct, for if it were, then example (16a) with unaccusative *pP* and the accusative Ground would receive its case from *v*, and therefore should

What emerges from this discussion is a clearer picture of what sort of scenarios develop when *p* is defective. Example (18) confirms our proposal with regard how to the unaccusative *pP* should behave when interacting with a Figure argument. As a result of this confirmation, namely if the *p* is a defective phase head, the following assumptions will also hold to be true:

- The Figure simply cannot be realized (regardless of which case is assigned)
- *Ent-* (in fact, *aus+p*) cannot assign case (dative) to the Ground (due to Burzio’s Generalization; compare Svenonius 2003).
- The Ground must be promoted to receive case by *v*.

The data in (19) show that *auspP* cannot accurately be classified as either transitive (19a) or unergative (19b). These sentences are used to show that our assumptions are correct that Class B verbs such as *entladen* ‘to unload’ are unaccusative and not transitive or unergative. In the *auspP* neither both arguments can be present (19a) nor just the Figure by itself (19b).

- (19) a. * *Sie ent-lädt dem Wagen die Kartoffeln.*
 she ent-load the.dat wagon the.ACC potatoes
- b. * *Sie ent-lädt die Kartoffeln.*
 she ent-load the.ACC potatoes

For Class C verbs, we propose that *pP* is unergative, i.e., transitive with a covert Ground. In this case, the P-element *aus* incorporates into the verb and it is the Tense-Feature on *v* that is responsible for assigning accusative case to the Figure and Ground is implicit. Once again, our proposal is consistent with Stiebels’ assertions that with this class of verbs (Class C), the applied object is not realized. Consider this final example:

- (20) *Die Piraten haben ein Boot entführt.*
 the pirates have a boot.ACC hijacked
 ‘The pirates have hijacked a boot.’

In (20), the ϕ -features on p are valued by the covert noun in order for the derivation to successfully converge at the interfaces. As predicted, the Figure must receive its case from a higher position in the structure.

4.2 Spell-out and *aus*-verbs and *ent*-verbs

One of the more daunting issues surrounding our analysis is the challenge of properly determining the spell-out properties of *auspP*, i.e., exactly when should this element be realized at PF as *aus* and when as *ent*-? Following our core proposal that we have set out from the beginning, we support the following hypothetical rule (see Sections 4.1.3 and 4.1.4 above for a more detailed explanation):

PF rule: spell out *aus* incorporated into V as *ent*-.

Since we envisage the movement of p as a syntactic operation, we can also place the following constraint on this movement type that requires one overt copy of this movement chain to surface at PF. In contrast, the preposition or particle *aus* is crucially not incorporated into the verb, (again, see Sections 4.1.3 and 4.1.4 for more details). As a result, *auspP* has three spell-out options, highlighted in (21):

(21)

Prefix <i>ent</i> -	<i>aus</i> incorporated into V
Particle <i>aus</i>	<i>aus</i> incorporated into unaccusative or unergative p
Preposition <i>aus</i>	<i>aus</i> incorporated into transitive p

The incorporation analysis championed here delivers a distinct advantage in the analysis of the close relationship that exists between *ent*- and *aus*-verbs since it can explain the different behavior of the prefix *ent*- and the particle/preposition *aus* with regard to stranding under verb-first and verb-second orders. This is especially observable with regard to the (in)separability of these prefixed verbs by means of morphological operations. Given that excorporation is not permitted here, the incorporated *aus* cannot be separated. This also holds for the morphological processes if we assume that morphological operations can be handled in the narrow syntax.

The correlation between the presence/absence of the incorporated *ent-* on V and the absence/presence of *aus* in *pP* can be further illustrated below (cf. also section 2).

- (22) a. **Er ent-nahm die Innereien aus dem Fisch.*
 he ent-took the_{.ACC} guts out the_{.DAT} fish
- b. **Er ent-lud das Auto aus.*
 he ent-loaded the_{.ACC} car out
- c. **Sie ent-steigt dem Auto aus.*
 she ent-climbs the_{.DAT} car out

Example (22a)=(3b) confirms our hypothesis that *ent-* and *aus* cannot co-occur. Example (22b) illustrates that the claim regarding the impossibility of co-occurrence of multiple copies of the same chain also holds for *ent-*verbs with unaccusative *pPs*, while (22c) demonstrates the validity of this claim with regard to intransitive verbs. Our hypothesis of one overt copy of *auspP* per chain also opens the door to an explanation regarding the correlation between the presence of *ent-* and the preposition-less dative on Ground arguments, as discussed in section 4.1.3. Since only one overt copy per chain is allowed and since under normal circumstances the highest copy is spelled out, the lower copies are deleted. Since the preposition *aus* assigns dative case, the preposition-less Ground argument receives dative case. As we will see in section 4.2.2, exceptions to this rule are examples such as (29), where both *ent-* and *aus* appear in the same sentence. These data are not a threat to our analysis, for we maintain that these examples are lexicalized.

4.2.1 *Aus* vs. *ent-* and the argument structure of *pP*

As the observant reader has most likely picked up on by this point, the choice to spell-out *ent-* or *aus* is dependent on the argument structure of *pP*. This claim can be easily demonstrated with the following data introduced earlier in the paper (cf. (2a), (3a)), but repeated for the sake of the reader. First, consider the data in (23); if *pP* is transitive both the Figure (locatum) and the Ground (relatum) are present and *aus* can be spelled out either as *aus* or *ent-* on *nehmen*:

- (23) a. *Er nahm die Innereien aus dem Fisch.* =(2a)
 he took the.ACC guts out the.DAT fish
 ‘He removed the guts from the fish.’
- b. *Er ent-nahm dem Fisch die Innereien.* =(3a)
 he ent-took the.DAT fish the.ACC guts
 ‘He removed the guts from the fish.’

Unlike the data in (23) which provides the option of spelling out *aus* as a preposition (cf. (23a)) or incorporating *ent-* into the verb (cf. (23b)) when *pP* is transitive, with unaccusative *pPs*, *aus* can only be spelled-out as the particle *aus*.

- (24) a. *Er nahm den Fisch aus.* =(2c)
 he took the.ACC fish out
 ‘He took the guts out of the fish.’
- b. **Er ent-nahm den Fisch.* =(16a)
 he ent-took the.ACC fish

Lastly, if *pP* is unergative, *aus* can only be realized at PF as the incorporated prefix *ent-*.

- (25) a. **Er nahm die Innereien aus.* (OK only if *Innereien* = Ground)
 he took the.ACC guts out
- b. *Er ent-nahm die Innereien.*
 he ent-took the.ACC guts
 ‘He took the guts out.’

Since *ent-* is in actuality incorporated *aus*, the data above suggest that *aus* cannot move out of the unaccusative *pP*, must move out of an unergative *pP* and can move out of a transitive *pP*. This cannot be analyzed solely by means of any selection process that takes place simply between the verb *nehmen* and *pP*, because this verb (like others) selects all three types of *pPs*, as the data show. As we demonstrate below with examples (26) – (28), other verbs can behave quite

differently; therefore, the movement of *aus* cannot be a general property of the *pP* (e.g., that only unergative *aus* must move).

(26) a. *Er lud das Gepäck aus dem Auto.*
 he loaded the.ACC luggage out the.DAT car
 ‘He unloaded the luggage from the car.’

b. **Er ent-lud dem Auto das Gepäck.*
 he ent-loaded the.dat car the.ACC luggage

(27) a. *Er lud das Auto aus.*
 he loaded the.ACC car out
 ‘He unloaded the car.’

b. *Er ent-lud das Auto.*
 he ent-loaded the.ACC car
 ‘He unloaded the car.’

(28) a. *Er lud das Gepäck aus.*
 he loaded the.ACC luggage out
 ‘He unloaded the luggage.’

b. **Er ent-lud das Gepäck.*
 he ent-loaded the.ACC luggage

The examples in (26) demonstrate that if *pP* is transitive, *aus* can be spelled out only as a preposition, whereas if *pP* is unaccusative, as is the case in (27), *aus* has the option of being spelled out either as the particle *aus* as well as the incorporated *ent-*. As illustrated in (28), if *pP* is unergative, *aus* can be spelled out only as a particle. Based on the data above, we can see that *aus* can only move out of an unaccusative *pP*, thus, the impossibility of the movement properties of *aus* must be encoded in the verb. The movement of *p* then can be interpreted as an instance of head-movement, driven by an EPP-feature (Chomsky 2000), e.g., *laden* ‘to load’ has the EPP-feature only when selecting the unaccusative *pP*. This implies that there are two factors involved in the selection and licensing of this structure: the verb and the type of *pP*; cf. Stiebels &

Wunderlich (1994), Zeller (1999) and McIntyre (2002), who show that there is a lexical dependency between preverbs and the appropriate verb. In conclusion, all of these observations can be parsimoniously grouped into our claim that only one spell out of *pP* is allowed per chain.

4.2.2 *Aus* vs. bare dative and animacy

Stiebels (1996, 110) points out that with strongly lexicalized verbs, the Ground is optional and can be expressed by a prepositional phrase:

- (29) *Sie sind aus dem Gefängnis entflohen.*
they are out the.DAT prison escaped
'They escaped from the prison.'

In certain cases, both *aus* and a bare dative noun are possible; however, they have a different interpretation: the bare dative noun has an animacy requirement, whereas the *auspP* is inanimate. While in example (30a) *Polizei* 'the police' means either policemen or the police force, in (30b) *Polizei* means the police building.

- (30) a. *Sie sind der Polizei entflohen.*
they are the.DAT police escaped
'They escaped the police.'
'They quit the police force.'
- b. *Sie sind aus der Polizei entflohen.*
they are out the.DAT police escaped
'They escaped from the police station.'

Consider the ungrammatical example in (31); this example shows that *Polizei* 'police' and *Gefängnis* 'prison' compete for the Ground position.¹¹ It seems that there is not room for two

¹¹ There seems to be certain variability in speaker judgments; not all native speakers judge (31) as ungrammatical. For instance, for Florian Schäfer (p.c.), it is not a fully ungrammatical (i.e., only marked); for Stiebels (1996, 110, (59f)) the same sentence with preterite is fully ungrammatical. The variability in speaker judgments could be based on the fact that only for some speakers the free dative reading is possible.

Ground arguments and *aus+p* cannot assign two instances of dative case. The explanation for the ungrammaticality of (31) is straightforward: if the preposition selects only one Figure and one Ground, which is plausible because *aus* is a two-argumental predicate, then the argument cannot be interpreted. Furthermore, the ϕ -features on *p* cannot be valued twice. Once valued, they do not act as an active Probe anymore, therefore two dative objects cannot co-occur (due to the Activation Condition (for the Probe)).

(31) **Sie sind der Polizei aus dem Gefängnis entflohen.*
they are the.DAT police out the.DAT prison escaped

Thus, it appears that the ϕ -features of *p* also agree with the Ground with regard to its animacy (e.g., [+ animacy]). Based on the interaction of *p* with the animacy-Feature, we witness the spell out properties of *aus+p* as follows:

- *Aus* is the spell-out product of the inanimate-Feature
- The null preposition is a spell-out of animate-Feature
- The difference is not visible in normal cases, because lower copies are not pronounced.

Data supporting the idea that animacy plays a role in determining the grammaticality of these structures could be the data below, which are a variation of the examples found in (20). According to Stiebels (1996, 111), in the case of her Class C verbs (i.e., *entführen* ‘kidnap’, *entlassen* ‘release’) the Ground argument can be expressed by a prepositional phrase in certain cases. Thus, the question is why e.g. (32a), with the *pP aus dem Hangar* ‘from/out of the hangar’ is grammatical and (32b), with the bare dative, ungrammatical. According to our analysis, *aus* spells out the inanimate-Feature and the null preposition the animate-Feature. This means that the data judgments hold up to expectation because *Hangar* ‘hangar’ bears an inanimate-Feature. If the Ground argument can get an animate interpretation, as the Lufthansa company in example (32c), then the sentence is grammatical, as predicted by our analysis.

- (32) a. ? *Die Piraten haben das Flugzeug aus dem Hangar ent-führt.*
 the pirates have the.ACC airplane from the.DAT hangar ent-driven
 ‘The pirates have removed the airplane from the hangar.’
- b. * *Die Piraten haben das Flugzeug dem Hangar ent-führt.*
 the pirates have the.ACC airplane the.DAT Hangar ent-driven
- c. ? *Die Piraten haben das Flugzeug der Lufthansa ent-führt.*
 the pirates have the.ACC airplane the.DAT Lufthansa ent-driven
 ‘The pirates have removed the airplane from the Lufthansa’s airforce.’
 ‘The pirates have hijacked the Lufthansa airplane.’

The data in this section reveal the following relevant factors for the spell-out of *ent-* and *aus*: First, the (non-)incorporation of this element into the verb; i.e., incorporation into the verb (morphologically, as an inseparable prefix) will always result in the PF relation of *ent-*. Second, the argument structure of both the verb and *pP* in question interact to determine the spell out properties of *aus+p*. Finally, the animacy of bare Ground arguments can also determine the spell out of one of the alternative forms; *aus* is the spell-out product of the inanimate-Feature, whereas the null preposition is the spell-out of the animate-Feature.

4.3 Boundedness and extraction

Aside from the spell-out properties of *aus+p*, it is also noteworthy to mention that both PF realizations, i.e., *aus* and *ent-*, block extraction (see also Section 3.1):

- (33) a. *Er nahm ein Buch über Autos aus dem Regal.*
 he took a.ACC book about cars out the.DAT shelf
 ‘He took a book about cars from the shelf.’
- b. * *Welchem Regal nahm er ein Buch über Autos aus?*
 which bookshelf took he a.ACC book about cars out?
- c. ? *Worüber nahm er ein Buch aus dem Regal?*
 about what took he a.ACC book out the.DAT shelf
 ‘About what did he take a book from the shelf?’

- d. ?* *Worüber ent-nahm er dem Regal ein Buch?*
 about what ent-took he the.DAT shelf a.ACC book

How can we explain the difference between example (33d) with the prefixed verb *entnahm* and example (33c) with the unprefix verb *nahm*? The core components of our analysis set forth here provide the necessary tools for accounting for the instances of extraction blocking. First, recall that the prefix *ent-* is incorporated *aus*. And the preposition *aus* blocks extraction, as shown by sentence (33b). We already know that prepositions bear a valued Tense-Feature and that the valued Tense-Feature on DPs is case. We also know that prepositional cases are bounded, because prepositions bear a Tense-Feature with the valued bounded, as discussed in section 3. Note that it has been shown in the literature that there is a relation between prepositional (non-structural) cases and definiteness or specificity as well as between islands and definiteness; see, e.g., Mohanan (1994), Starke (2001), Danon (2006). The following example with the adverbial test repeated from footnote 3 demonstrates that the preposition *aus* also brings about boundedness in the verbal domain. As shown in (34a), the unprefix predicate *lief* ‘ran’ is compatible only with the *for*-adverbial *zwei Stunden* ‘two hours’. In contrast, as illustrated by (34b), the predicate with the incorporated *aus* is compatible only with the *in*-adverbial.¹² This means that the prefixed predicate is telic (bounded).

- (34) a. *Er lief zwei Stunden / *in zwei Stunden.*
 he walked two hours in two hours
 ‘He walked two hours/*in two hours.’
- b. *Er ent-lief *zwei Stunden / in zwei Stunden.*
 he ent-walked two hours in two hours
 ‘He escaped *two hours/in two hours.’

Having said this, we want the value of the Tense-Feature to depend on the incorporated *aus*. Concretely, the Tense-Feature on *v* must be unbounded if there is no incorporated *aus* on the

¹² Some speakers prefer (34b) with the perfect:

(i) *Er ist in zwei Stunden ent-laufen.*
 he is in two hours ent-walk
 ‘He escaped in two hours.’

verb. As already mentioned in section 4.1.1, in this respect, we follow Kratzer (2007 and references therein), who argues that the denotation of verb roots is cumulative from the start. When v selects VP and there is no *aus* on V, the unvalued Tense-Feature on v is valued as unbounded (cumulative) and v then assigns unbounded accusative; as a result, extraction is possible as in (33c). However, when *aus* does incorporate into V, its valued Tense-Feature values the Tense-Feature on v as bounded and v then assigns bounded accusative. Consequently, extraction is not possible, as shown in example (33d). Similar effects with extraction and (im)perfectivity are observable in Russian (Romanova 2007) and Czech (Biskup 2009).¹³

The notion of how extraction is blocked in this analysis resembles at first sight certain instances of intervention effects involving the Probe-Goal system as proposed by Carstens (2003) and Van Koppen (2005) to name a few. Turning to Carstens' account, she maintains that complementizer-agreement (hereafter C-agreement) in Bantu languages cannot hold up in certain constructions. For example, when the head of the CP possesses an uninterpretable agreement feature (or set of agreement features; ϕ -features) that must be valued, it will seek out a licit Goal that is the subject of a sentence (i.e., most like in Spec,TP). Carstens demonstrates that whenever a prepositional phrase (PP) or adverbial phrase (AdvP) intervened, these XPs were shown to function as some sort of barrier for the Probe-Goal relation between C^0 and the subject in Spec,TP (she hypothesizes that the intervening PP or AdvP possesses some sort of partial Case-Feature).¹⁴ The situation at hand with the extraction data presented in this section not only

¹³ The following Czech example shows that there are two types of structural accusative and that (non-)islandhood of accusative DPs is dependent on the value of their Tense-Feature. Extraction from a DP with the perfective (bounded) structural accusative assigned by the prefixed (i.e. perfective) verb in (ib) is worse than extraction from a DP with the imperfective (non-bounded) structural accusative assigned by the unprefixed (i.e. imperfective) verb in (ia).

- (i) a. [O čem]_i Pavel psal [dopis t₁]?
 about what Pavel_{NOM} wrote letter_{ACC}
 'About what was Pavel writing a/the letter?'
 b. ?? [O čem]_i Pavel do-psal [dopis t₁]?
 about what Pavel_{NOM} to-wrote letter_{ACC}
 'About what did Pavel write a/the letter?'

¹⁴ This proposal also has some shortcomings that are yet to be fully addressed in the literature. For example, Van Koppen (2005) observes that although it is consistent that PPs and AdvPs function as barriers in Germanic languages exhibiting C-agreement (note: Carstens' study focused primarily on Bantu languages), intervening focus particles do not induce these blocking effects. Second, Van Koppen also maintains that although the C-Spec,TP and v -Spec, v P should be structurally identical (especially in a version of the Minimalist Program that adopts Chomsky's notion of (strong) phases), the same intervention effects; namely, those involving an intervening PP or AdvP in the lower (v P) phase, do not result in a barrier between the Probe and Goal as in the higher (CP) phase.

resembles Carstens’ proposal, but also previous long-standing principles in derivational syntax (e.g., *The A-over-A Principle*¹⁵ and *Minimal Link Condition*¹⁶ MLC) and their reconfiguration to fit within a phase-based system (e.g., *Phase Impenetrability Condition*¹⁷ PIC and Fortuny’s *Relativized Opacity Principle*¹⁸ ROP) to derive the successive cyclic nature of derivations. Consider the tree structure in (35) schematizing the puzzling situation behind the extraction blocking in the examples in (33).

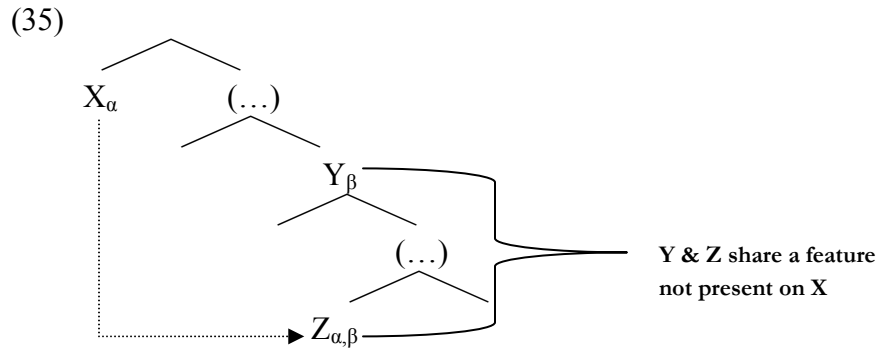

¹⁵ *The A-over-A Principle* (Chomsky 1964)

If a phrase X of category A is embedded with a larger phrase ZXW which is also of category A , then no rule applying to the category A applies to X but only to ZXW .

¹⁶ *The Minimal Link Condition* (MLC) (Chomsky 1995b, 311)

K attracts α if there is no β , β closer to K than α , such that K attracts β .

¹⁷ *Phase Impenetrability Condition* (PIC) (Chomsky 2001, 14)

In a phase α with a head H , the domain of H is not accessible to operations outside of α , only H and its edge are accessible to such operations.

¹⁸ *Relativized Opacity Principle* (ROP) (Fortuny 2008, 92)

In a syntactic object $[_{a1P} [\alpha_1 \dots [_{a2P} \Delta [_{a2} \Gamma]]]]$

- where:
- (i) α_1 and α_2 are two probes of the same type α each projecting an αP
 - (ii) Δ is SPEC- α_2 and Γ is α_2 -COMPL, and
 - (iii) $\exists \delta$. δ is a constituent of Δ and $\exists \gamma$: γ is a constituent of Γ ,

α_1 can probe Δ or Γ if they provide a suitable token for α_1 , but it cannot readily probe γ or δ

According to Fortuny (2008, 92), “According to this definition, the factor that decides whether a feature α_1 of type α can readily probe a goal is not being inside or outside the search domain of α_2 , but their relative depth in the α_2 -projection whose label is of the same type as the searching probe α_1 . $\alpha_2 P$ does not render the complete Δ and Γ opaque to α_1 , but search in them becomes difficult. In other words, α_1 manages to detect Δ and Γ but not δ and γ because Δ and Γ are located on a more superficial layer than δ and γ .”

Remaining consistent with Minimalist terminology, assume that X stands for “probe”, Y for “intervening category”, and Z “goal” in (35) (with the caveat, that perhaps none of these commonly held terms aptly apply for the situation at hand). The crux of the matter is as follows: The Probe-type feature (α) is only present on X and Z, but crucially *not* on Y. In this respect, there is not intervention imposed on the Probe-Goal relationship between X and Z via some sort of unwanted intervention effect. The intervening element, Y, does however possess (at least) one feature (β) that is of the same type as a feature of Z (represented above as α , β). In this strange course of events, the bond between Y and Z creates a union that enables X to agree with Z, however, it prevents X from extracting Z. Here, Y and Z form a unit which we refer to as a *hurdle* that prevents X from entering into an otherwise licit agreement relation with Z that would enable it to extract Z from its position. Note that our proposal of the notion of a *hurdle* is somewhat of an extension of Carstens’ proposal outlined above to the extent that it adopts her notion of intervention effects in a Probe-Goal system and attempts to explain why extraction is not possible out of such units; however below, we will also demonstrate how *hurdles* can capture the exact opposite effects as those observed by Carstens. Recall that for Carstens, agreement between a Probe and a Goal cannot take place if an intervening object bearing the relevant feature intervenes and that her approach is mute on the topic of extraction. Our notion of *hurdles* adopted here focuses on the featural bond between the possible intervener Y and the Goal Z. We define the notion of *hurdle* in (36) below:

(36) *Hurdle*

In a hierarchical configuration [X [Y [Z ...]]] where:

- (i) X c-commands both Y and Z and Y dominates Z,
- (ii) X possesses an unvalued Probe-feature that can be valued by a feature on Z,
- (iii) There exists an identical feature on Y and Z that is not identical to the unvalued Probe-feature on X, and
- (iv) The feature of Y identical to the feature on Z creates an extraction boundary for Z.

Hurdles in this respect are derivationally compiled based on the feature identity of local syntactic objects and derivationally create opaque domains through which Z cannot penetrate in the case

of extraction. For our analysis in this paper, the feature in question are T(ense)-Features with the valued bounded present on Y and Z, and given that both of them would be valued by this stage of the derivation, Chomsky (2000 *et seq.*) would maintain that these elements are no longer active in the syntactic derivation. In this respect, the situation at hand resembles defective intervention effects; the key difference, however, for our situation here is that the feature on X (which is a *wh*-Feature in the relevant data) is in fact different from the two features relevant for the intervention effect (i.e., T-Features in our case). Thus, what we are dealing with is perhaps an extended variant of intervention effects, yet we acknowledge that it is also a phenomenon that is unique and worthy of serious pursuit in future studies.

Let's now turn our attention to how the notion of a *hurdle* can accurately describe and account for the structure present in our data displaying DP- and *pP*-structures. Consider example (33b); the structure of *pP* with the relevant movement would most likely be as described in (37):

(37) [_{CP} welchem Regal ... [_{pP} ~~welchem Regal~~ [_{pP} aus+*p* [_{PP} aus [~~welchem Regal~~]]]]]]

The *hurdle* is created at the step of [_{pP} welchem Regal [_{pP} aus+*p*]]; at this derivational step the bond between Y and Z (with regard to their bounded Tense-Features) generates the opaque extraction domain. At this derivational step the valued Tense-Feature with the value bounded present on *pP* generates the opaque extraction domain, as a result the Tense-Feature of the moved *aus*-element projected on *pP* functions as the blocker in this configuration. Note that if *welchem Regal* stays in *pP*, the sentence is grammatical. In the case of the ungrammatical (33d), the problem is that *pP* (*worüber*) with the bounded valued Tense-Feature – i.e. Z according to definition (36) - is moved out of the direct object (*ein Buch*) with the bounded valued Tense-Feature (bounded accusative) - i.e. out of Y with the identical feature according to definition (36). When the Tense-Feature on the object is unbounded - i.e. it is not identical to the feature on Z (specifically, to its value) – the sentence is only slightly marked, as shown by (33c).

In conclusion to our discussion on the notion of *hurdle* as a potential derivational extraction barrier, we maintain that its mechanics are in line with core Minimalist principles that hold Probe-Goal relations to exist (cf. Chomsky 2000 *et seq.*). In many respects the situation at hand presented by these extraction data is an extension of Chomsky's (1964) *A-over-A Principle* (cf.

fn. 15). Our notion of *hurdle* functions as a descriptor of how/why extraction out of certain units is not possible.

5. CONCLUSION

In this paper, we advance a derivational approach to the *aus/ent*-alternative in German particle and prefixed verbs that uphold the following claims:

- The prefix *ent-* is the preposition *aus* incorporated into the verb.
- The resulting spell-out of *aus* is determined by several different factors.
- The bounded valued T-Feature on *aus* is responsible for boundedness effects.

The principal advantage our analysis has is rather than arguing for separate underlying structures for prefixed and particle verbs, we propose that particles and prefixed forms (which also surface as prepositions in German) can be subsumed as P-elements that share common morphosyntactic features and participate in Probe-Goal relations. Our derivational analysis of the *ent-/aus*-alternation - rather than exploring base-structure distinctions - reduces to two types of the *pP* argument structure and possibility of the preposition to move. The preposition and its arguments are endowed with ϕ -Features and the Tense-Feature, which are responsible for deriving the appropriate case patterns and the definiteness effects. Depending on whether the preposition *aus* incorporates into the verb or whether it stays in *pP*, it emerges either as the prefix *ent-* or as the particle/preposition *aus*. Then, depending on whether the preposition incorporates into the transitive *p* or the intransitive *p*, it emerges either as the preposition *aus* or as the particle *aus*. To account for the extraction data, we introduced the notion of *hurdles*, i.e. extraction barriers that are the result of the unique featural composition of a Probe-like element X, an intervening element Y, and a Goal-like element Z, where X and Z share a matching feature; however, Y and Z share an identical feature (which X does not), which creates an extraction barrier.

WORKS CITED

- Baker, M. 1988. *Incorporation: A theory of Grammatical Function Changing*. Chicago: The University of Chicago Press.
- Baker, M. 2008. *The Syntax of Agreement and Concord*. Cambridge: Cambridge University Press.

- Biskup, P. 2009. Prefixes as Prepositions and Multiple Cases. In: G. Zybatow, U. Junghanns, D. Lenertová & P. Biskup (eds.), *Studies in Formal Slavic Phonology, Morphology, Syntax, Semantics and Information Structure. Proceedings of FDSL 7, Leipzig 2007*. Frankfurt am Main: Peter Lang, 3-17.
- Biskup, P. to appear. P(refixe)s and P(reposition)s. In: B. Dvořák (ed.), *Proceedings of the 2nd Congress of Slavic Linguistic Society*.
- Bowern, C. & G. Aygen-Tosun 2000. Titan's Tensed Prepositions. In: A. Okrent & J. P. Boyle (eds.), *Proceedings of the 36th Chicago Linguistics Society*. Vol. 2. Chicago Linguistics Society, 35-48.
- Brennan, J. 2008. Irish Prepositions: Agreement and Impoverishment. In: Ch. B. Chang & H. J. Haynie (eds.), *Proceedings of the 26th West Coast Conference on Formal Linguistics*. Somerville, MA: Cascadilla Proceedings Project, 105-113.
- Carstens, V. 2003. Rethinking complementizer agreement: Agree with a case-checked goal. *Linguistic Inquiry* 34.3, 393-412.
- Chomsky, N. 1964. *Current Issues in Linguistic Theory*. The Hague: Mouton.
- Chomsky, N. 1981. *Lectures on Government and Binding*. Dordrecht: Foris.
- Chomsky, N. 1995a. Bare Phrase Structure. In: G. Webelhuth (ed.), *Government and Binding Theory and the Minimalist Program*. Oxford: Blackwell, 383-439.
- Chomsky, N. 1995b. *The Minimalist Program*. Cambridge, MA: MIT Press.
- Chomsky, N. 2000. Minimalist Inquiries: The Framework. In: R. Martin, D. Michaels & J. Uriagereka (eds.), *Step by Step: Essays on minimalist syntax in honor of Howard Lasnik*. Cambridge, MA: MIT Press, 89-156.
- Chomsky, N. 2001. Derivation by Phase. In: M. Kenstowicz (ed.), *Ken Hale: A Life in Language*. Cambridge, MA: MIT Press, 1-52.
- Danon, G. 2006. Caseless nominals and the projection of DP. *Natural Language & Linguistic Theory* 24.4, 977-1008.
- den Dikken, M. 1995. *Particles: on the syntax of verb-particle, triadic and causative constructions*. New York: Oxford University Press.
- Emonds, J. E. 1985. *A Unified Theory of Syntactic Categories*. Foris: Dordrecht.
- Fortuny, J. 2008. *The Emergence of Order in Syntax*. Amsterdam: John Benjamins.
- Gehrke, B. 2008. *Ps in Motion: On the Semantics and Syntax of P Elements and Motion Events*. Utrecht: LOT Dissertation Series, Netherlands Graduate School of Linguistics.
- Harlow, R. 2007. *Māori: A Linguistic Introduction*. Cambridge: Cambridge University Press.
- Haumann, D. 2002. The Projections of Temporal Prepositions. In: H. Cuyckens & G. Radden (eds.), *Perspectives on Prepositions*. Tübingen: Niemeyer, 25-45.
- Jackendoff, R. 1973. Base Rules for PPs. In: S. R. Anderson & P. Kiparsky (eds.), *A Festschrift for Morris Halle*. New York: Holt, Rinehart, and Winston, 345-356.
- Kluge, F. 2002. *Etymologisches Wörterbuch der deutschen Sprache*. 24. Auflage. Berlin: Walter de Gruyter.
- Kratzer, A. 2007. On the Plurality of Verbs. In: J. Dölling, T. Heyde-Zybatow & M. Schäfer (eds.), *Event Structures in Linguistic Form and Interpretation*. Berlin, New York: Mouton de Gruyter, 269-300.
- Lüdeling, A. 2001. *On Particle Verbs and Similar Constructions in German*. Stanford: CSLI.

- Matushansky, O. 2002. On formal identity of Russian prefixes and prepositions. In: A. Csirmaz, Z. Li, A. Nevins, O. Vaysman & M. Wagner, (eds.), *Phonological Answers (and their corresponding questions)*. MITWPL 42, Cambridge MA, 217-253.
- McIntyre, A. 2002. Idiosyncrasy in particle verbs. In: N. Dehé, R. Jackendoff, A. McIntyre & S. Urban (eds.), *Verb-Particle Explorations*. Berlin/New York: Mouton de Gruyter, 95-118.
- Miller, D. G. 1993. *Complex Verb Formation*. Amsterdam/Philadelphia: John Benjamins Publishing Company.
- Mohanan, T. 1994. *Argument Structure in Hindi*. Stanford: CSLI Publications.
- Pesetsky, D. & E. Torrego 2004. Tense, Case, and the Nature of Syntactic Categories. In: J. Guéron & J. Lecarme (eds.), *The syntax of Time*. Cambridge, MA: MIT Press, 495-539.
- Pesetsky, D. & E. Torrego 2006. Probes, Goals and Syntactic Categories. In: Y. Otsu (ed.), *Proceedings of the Seventh Tokyo Conference on Psycholinguistics*. Tokyo: Hituzi Syobo Publishing Company, 25-61.
- Roberts, I. 2001. Head Movement. In: M. Baltin & Ch. Collins (eds.), *Handbook of Syntactic Theory*. Oxford: Blackwell Publishers, 113-147.
- Romanova, E. 2007. *Constructing perfectivity in Russian*. Ph.D. dissertation, University of Tromsø.
- Starke, M. 2001. *Move Dissolves into Merge*. Ph.D. dissertation, University of Geneva.
- Stiebels, B. 1996. *Lexikalische Argumente und Adjunkte: zum semantischen Beitrag von verbalen Präfixen und Partikeln* [Studia Grammatica 39]. Berlin: Akademie Verlag.
- Stiebels, B. 1998. Complex denominal verbs in German and the morphology-semantics interface. In: G. Booij & J. van Marle (eds.), *Yearbook of Morphology 1997*, 265-302.
- Stiebels, B. & D. Wunderlich 1994. Morphology feeds syntax: the case of particle verbs. *Linguistics* 32, 913-968.
- Svenonius, P. 2003. Limits on P: filling in holes vs. falling in holes. In: A. Dahl, K. Bentzen & P. Svenonius (eds.), *Nordlyd 31 (2). Proceedings of the 19th Scandinavian Conference of Linguistics*, 431-445.
- Svenonius, P. 2007. *Adpositions, Particles, and the Arguments they Introduce*. In: E. Reuland, T. Bhattacharya & G. Spathas (eds.), *Argument structure*. Amsterdam: John Benjamins, 63-103.
- Talmy, L. 1975. Semantics and syntax of motion. In: J. P. Kimball (ed.), *Syntax and Semantics*, Vol. 4. New York: Academy Press, 181-238.
- Van Koppen, M. J. 2005. *One probe – two goals: Aspects of agreement in Dutch dialects*. Dissertation, University of Leiden. LOT-Publications 105.
- Wunderlich, D. 1987. An investigation of lexical composition: the case of German be-verbs. *Linguistics* 25, 283-331.
- Wunderlich, D. in press. Lexical decomposition. Submitted to *The Oxford Handbook of Compositionality*. Oxford: Oxford University Press.
- Zeller, J. 1999. Particle verbs, local domains, and a theory of lexical licensing. Ph.D. dissertation, University of Frankfurt.
- Zeller, J. 2001. Lexical particles, semi-lexical postpositions. In: N. Corver & H. van Riemsdijk (eds.), *Semi-lexical categories*. Berlin: Mouton, 505-549.