

# Prefixes, Scales and Grammatical Theory

Petr Biskup, Gerhild Zybatow\*  
Universität Leipzig

This paper is concerned with the status of prominence scales in grammatical theory and investigates the interaction of prefixation and the theta role scale and the case scale in Russian and Czech. We make a difference between particular scales - such as the case scale or the theta role scale - and the complex scale, which is composed of the two particular scales. We argue that the theta role scale and the case scale can be taken to be a reflection of the syntactic structure and that they are determined by syntacticosemantic properties of the clause structure. The complex scale is a more interesting object. This scale is independent of the syntactic structure and represents alignments of members of the theta role scale with members of the case scale. Although both types of scales are not necessary for deriving particular sentences, it is interesting that the complex scale – which is independent of the syntax - can predict the grammatical/markedness status of particular sentences. Thus, the complex scale, which seems to express more general patterns, also has a certain explanatory power in language. We argue that the form of the complex scale of a particular sentence parallels grammatical principles and operations. There is a correlation between the type of the complex scale tree, syntactic operations and the morphological marking/grammatical status of the sentence. We show that only certain types of crossings in the complex scale tree, which correspond to certain types of syntactic processes, are allowed in the grammar.

## 1. Data

### 1.1. Intransitive verbs

#### 1.1.1. Unprefixed intransitive verbs

We begin with unprefixed intransitive verbs. The argument of intransitive verbs typically bears nominative case. This is shown in (1) for unergative verbs and in (2) for unaccusative verbs. The (b) examples demonstrate that the single argument cannot bear the accusative marker. There are only a few unaccusative verbs assigning accusative case in Czech.

- (1) a. Pavel pracuje. (CZ)  
Pavel.nom works  
'Pavel works.'  
'Pavel is working.'
- b. \*Pavl-a pracuje.  
Pavel-acc works
- (2) a. Oper-a hoří. (CZ)  
Opera-nom burns  
'The Opera is burning.'  
'The Opera burns.'
- b. \*Oper-u hoří.  
Opera-acc burns

There are also special classes of verbs, such as unaccusative psych verbs, which take a nominative object (patient) and a dative experiencer, as shown in (3). Example (3b)

---

\* We would like to thank the audience at the Workshop on Scales (Leipzig, 2008) for helpful comments and suggestions. Particular thanks go to Marc Richards.

demonstrates that the patient argument cannot be assigned accusative case, (3c) shows the same for the experiencer argument and (3d) shows that if both arguments are realized as prepositional phrases, the verb bears default agreement.<sup>1</sup>

- (3) a. Pavl-ovi se líbil-a ta nová pohádk-a. (CZ)  
 Pavel-dat self liked-sg.f the new story-sg.f.nom  
 ‘Pavel enjoyed the new story.’  
 b. \*Pavl-ovi se líbil-a tu novou pohádk-u.  
 Pavel-dat self liked-sg.f the new story-sg.f.acc  
 c. \*Pavl-a se líbil-a ta nová pohádk-a.  
 Pavel-acc self liked-sg.f the new story-sg.f.nom  
 d. Pavl-ovi se líbil-o v Praze.  
 Pavel-dat self liked-sg.n in Prague  
 ‘Pavel enjoyed Prague.’

Another verbal class with unpredictable cases is the class of experiencer verbs taking a nominative patient and an accusative experiencer, as illustrated in (4). Example (4b) shows that cases on the arguments cannot be switched. The experiencer cannot be marked by nominative and the patient cannot get the accusative case. (4c) then shows that in addition to the nonstructural accusative on *Pavel*, the predicate cannot take another accusative argument.

- (4) a. Pavl-a bavil-a ta nová pohádk-a. (CZ)  
 Pavel-acc interested-sg.f the new story-sg.f.nom  
 ‘Pavel was interested in/enjoyed the new story.’  
 b. \*Pavel bavil tu novou pohádk-u.  
 Pavel.nom interested.sg.m the new story-sg.f.acc  
 c. \*Pavl-a bavil-o tu novou pohádk-u.  
 Pavel-acc interested-sg.n the new story-sg.f.acc

### 1.1.2. Prefixed intransitive verbs

In this section, we investigate the question of what happens if a prefix is attached to intransitive verbs. As illustrated in example (5a), the stative predicate *měrz* cannot be combined with the resultative prepositional phrase *v ajsberg*. However, the prefix *v-* attached to the verb can license the directional prepositional phrase, as shown in (5b).

- (5) a. On mērz (\*v ajsberg) (R)  
 he froze in iceberg.acc  
 b. On v-mērz v ajsberg  
 he in-froze in iceberg.acc  
 ‘He froze in the/a iceberg.’

In cases where a directional prepositional phrase can be combined with an unprefixated verb, prefixation brings about the result implication. In (6a), there is an imperfective paradox; although there is an endpoint present in the sentence, it does not mean that *on* reached *Moscow*. In contrast, in (6b) prefix *v-* brings about the telic type of perfectivity and the sentence implies that he reached *Moscow*.

<sup>1</sup> We assume that dative arguments are prepositional phrases, hence *Pavlovi* in (3) is a prepositional phrase with a covert preposition (see e.g. Emonds 2007a, chapter 5 and 2007b).

- (6) a. On echal v Moskv-u. (R)  
 he drove in Moscow-acc  
 ‘He was driving to Moscow.’  
 b. On v-echal v Moskv-u.  
 he in-drove in Moscow-acc  
 ‘He drove to Moscow.’

The following example shows that prefixes can also license accusative objects. In (7b) verb *spal* with the completive prefix *do-* can be combined with the accusative object *noč*, in contrast to the unprefixated verb in (7a).

- (7) a. On spal (\*noč). (R)  
 he slept night.acc  
 b. On do-spal noč.  
 he to-slept night.acc  
 ‘He slept till the end of the night.’

## 1.2. Transitive verbs

### 1.2.1. Unprefixated transitive verbs

Let us now look at unprefixated transitive predicates. Transitive verbs take a nominative and accusative argument. The nominative case is aligned with the agent argument and the accusative case with the patient argument, as demonstrated in (8a). Example (8b) shows that the reversed alignment is not possible. This alignment is only possible with passive morphology and the instrumental agent, as illustrated in (8c).

- (8) a. Pavel bil Jirk-u. (CZ)  
 Pavel.nom beat Jirka-acc  
 ‘Pavel beat Jirka.’  
 b. Pavel bil Jirk-u.  
 Pavel.nom beat Jirka-acc  
 \* ‘Jirka beat Pavel.’  
 c. Pavel byl bit Jirk-ou.  
 Pavel.nom was beaten Jirka-instr  
 ‘Pavel was beaten by Jirka.’

### 1.2.2. Prefixated transitive verbs

Prefixes attached to transitive verbs either just induce perfectivity or they also add a prepositional phrase, as shown in (9). Example (9c) demonstrates that the nominative case is typically aligned with the agent theta role, the accusative case with patient and the oblique case with the goal prepositional phrase. As shown in example (9d), the reversed alignment of the patient argument and the goal argument is not possible.

- (9) a. On pisal svoe imja. (R)  
 he wrote self name.acc  
 ‘He was writing his name.’  
 b. \* On v-pisal svoe imja.  
 he in-wrote self name.acc  
 c. On v-pisal svoe imja v knig-u početa.  
 He in-wrote self name.acc in book-acc of honor  
 ‘He wrote his name in the book of honor.’

- d. \* On v-pisal v imja knjig-u početa.  
 He in-wrote in name.acc book-acc of honour

## 2. Scales

### 2.1. Scales generally

Scales can be treated as hierarchies,<sup>2</sup> and hierarchies can be treated as a certain type of graph. In this paper, we will represent scales as trees, connected acyclic graphs, as schematized in (10). Taking (10) into consideration, it is clear that scales have a structure. Relations between scale members then can be based on structural relations as e.g. c-command.

(10)

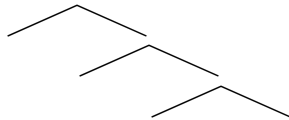

Let us now turn to particular prominence scales. For the case scale, we make use of Bobaljik's (2008a, 2008b) case scale, as shown in (11a).<sup>3</sup> (11a) means that nominative case is more prominent than accusative case and that accusative case in turn is more prominent than dative or oblique case. As for the theta role scale, we follow *Forschergruppe 742* (2005); consider (11b).

(11) Prominence scales:

- a. Case scale: nominative > accusative > dative/oblique
- b. Theta role scale: agent > patient > goal

Combining the tree of c-command relations in (10) with the scales in (11) results in (12a) and (12b). The nominative case, since it is the most prominent scale member, c-commands the accusative case and the dative or oblique case and the accusative case in turn c-commands the dative or oblique case. In a parallel fashion, the agent theta role, which is the most prominent one, c-commands the patient theta role and the goal theta role, and the patient theta role in turn c-commands the goal theta role.

(12) a.

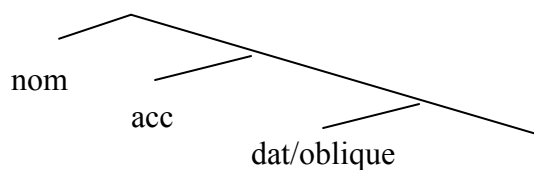

b.

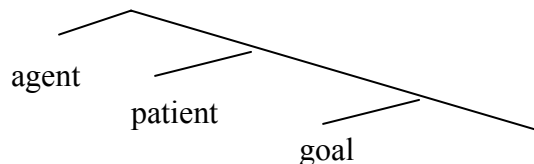

To get more interesting theoretical statements, the particular scales in (12a) and (12b) can be conjoined. Thus, if we keep the c-command relations between scale members and map members of one scale onto members of the other scale, we get the complex scale tree (13), as

<sup>2</sup> Certain approaches even use the term *hierarchy* instead of *scale*.

<sup>3</sup> Compare also the more general Case Realization Hierarchy (i) from Bobaljik (2008a, 2008b) and similarly Bittner & Hale (1996) and Marantz (2000). For our purposes, the case scale in (11a) is sufficient.

(i) unmarked case > dependent case > lexical case

shown below. This complex scale tree in fact represents the unmarked harmonic alignment of six particular scale members.<sup>4</sup>

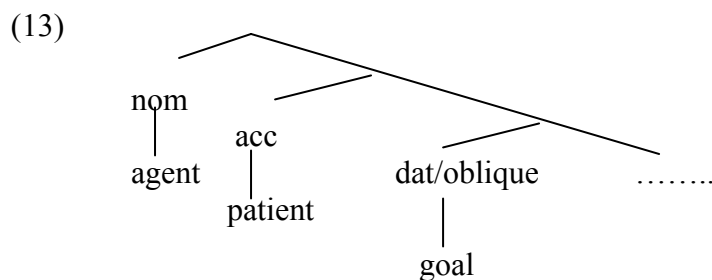

The generalization is that the unmarked alignment is a mapping between scale trees without crossing. To give a few examples of what we mean by a crossing, consider (14). In (14a) there is a one-way crossing, in (14b) a two-way crossing and in (14c) a two-way crossing, which in addition is reciprocal; we will see other types of complex scale trees in subsequent sections. A marked alignment then is mapping between scale trees with a crossing.<sup>5</sup>

(14) a. One-way crossing

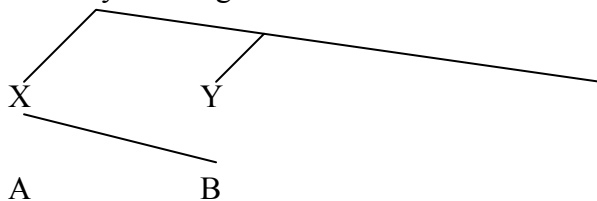

b. Two-way crossing

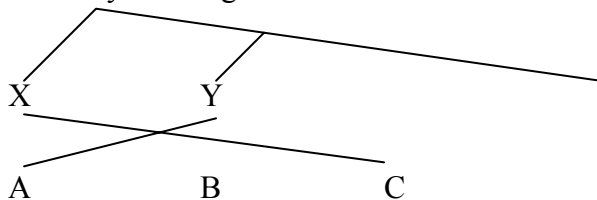

c. Two-way reciprocal crossing

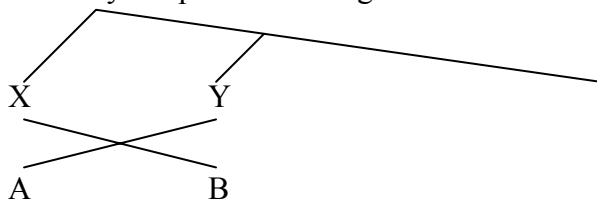

In the complex scale tree, the degree of markedness can also be determined by the c-command relations. The patient theta role c-commands the goal theta role in the complex scale tree; therefore a goal with the nominative marker is more marked than a patient with the nominative marker (and a patient with the nominative case would be more marked than an agent), as demonstrated in (15) also by the crossings of different lengths.

<sup>4</sup> According to Aissen (2003, 441), harmonic alignment applies to pairs of scales and aligns each element on one with each element on the other and then generates constraint subhierarchies expressing the relative markedness of each such association.

<sup>5</sup> From the formal point of view, complex scale trees with crossings do not always satisfy the criteria for a tree but since nothing hinges on it, we will call them trees as well.

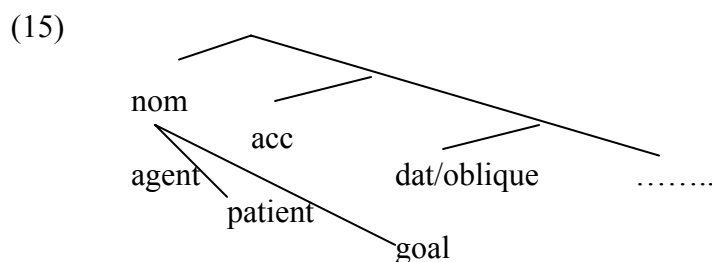

Markedness or crossings can go in both directions. Upwards, as e.g. in the case of passivization in Czech, where the patient gets the nominative case, or downwards, as e.g. in the case of the antipassive voice in West Greenlandic, where the patient argument gets the instrumental case. Note that this says nothing about the direction of operations in syntactic trees.

Languages generally do not have to express whole scales. Consider e.g. case marking in ergative languages versus non-ergative languages. Languages also do not have to use whole scales in every sentence, as is clear e.g. from cases of intransitive sentences.

## 2.2. Scales in a minimalist analysis

In this section, we deal with particular scales and show that both the theta role scale and the case scale are a reflection of the syntactic structure, hence that they are determined by syntacticosemantic properties of the clause structure. The syntactic tree in (16) shows that both prominence scales in fact emerge from the syntactic structure and that c-command relations between members of particular scales are preserved. We see that the theta role scale is sandwiched inside the case scale. This is a consequence of the fact that structural cases are structurally higher than nonstructural cases.<sup>6</sup> Specifically, structural cases are assigned or valued in the functional domain by the tense head and the aspectual head through the operation Agree and languages may differ with respect to whether or not the agreeing arguments move to the specifier position of the appropriate projection.<sup>7</sup> And nonstructural cases are assigned in the theta domain ( $\nu$ P) by the verb or prepositions through the operation External Merge.<sup>8</sup> One observes that only the goal argument and the dative or oblique case are mapped structurally, with unmarked harmonic alignment. The reason for this is that in the case of prepositional cases the case goes hand in hand with the theta role.

<sup>6</sup> We leave aside adjunction here.

<sup>7</sup> For arguments supporting the claim that structural accusative is assigned in AspP in Russian and Czech, see Biskup (to appear).

<sup>8</sup> Compare also Babby's (1987) Syntactic Case Hierarchy and Franks's (1995) Case Hierarchy (ii):

- (i) Lexical Case takes precedence over a Configurational Case.
- (ii) a. the +Oblique Cases are assigned at D-Structure,  
b. the -Oblique Cases are assigned at S-Structure.

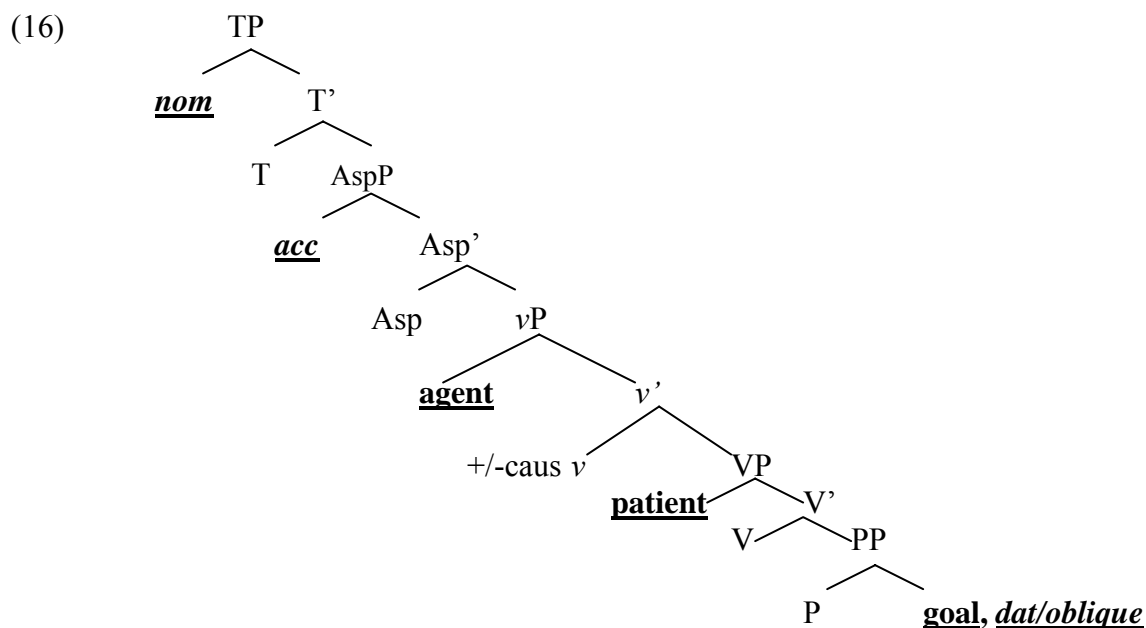

The two prominence scales are (at least partially) determined by semantic properties of the syntactic structure. It is a well-known fact that there is a connection between structural cases and tense and aspect (see e.g. Pesetsky & Torrego 2004). It has also been argued that tense and aspect relate two times (see e.g. Klein 1995, Demirdache & Uribe-Etxebarria 1997). The head T can be treated as a dyadic operator that takes the reference time, which is related to AspP, and the speech time, and similarly the head Asp takes the event time, which is anchored in the verbal domain, and the reference time. Thus, T scopes over Asp and Asp over (the decomposed) vP. Therefore the nominative case, which is connected to T, c-commands - is more prominent than - the accusative case, which is assigned in AspP. The accusative case then is more prominent than the dative or oblique case, which is assigned in vP.

Parallel reasoning applies to the theta role scale. We assume that the event structure, i.e. vP, is decomposed. The (non-)causative v scopes over the process or stative V and V scopes over PP. Evidence for the event decomposition and ordering of subevents comes e.g. from the contrast between the restitutive and the repetitive reading of the scope-taking adverb *again*. Stechow (1996) shows that in the restitutive reading, in contrast to the repetitive reading, *again* only scopes over VP (and PP) to the exclusion of vP. If theta roles are assigned configurationally as a result of DP-Merger (see Hale & Keyser 1993 or Ramchand 2008), then the agent theta role in Spec,vP c-commands - is more prominent than - the patient theta role in Spec,VP and the patient theta role in turn is more prominent than the goal theta role in PP.

### 3. Scales and derivations

In this section, we deal with syntactic derivations and complex scale trees of particular sentences. Although the complex scale tree is not part of the syntactic derivation and is not necessary for deriving particular sentences, its form corresponds to certain syntactic processes and the grammatical/markedness status of the sentence.

#### 3.1. Unprefixed intransitive verbs

We saw in section 1 that the single argument of intransitive verbs is typically realized as nominative. The natural question arises: Why? A possible answer is because nominative is the most prominent case. But how does it work?

We need to introduce some basic properties of our theoretical framework. Pesetsky & Torrego (2004, 2006) argue that there is a relation between the nominative case and the tense properties of the sentence and between the accusative case and aspectual properties of the

sentence and propose that structural case is an unvalued Tense feature on the nominal head N or D and that it is valued by head T and T<sub>0</sub> (i.e. the aspectual head). Biskup (submitted, to appear) extends their proposal and suggests that all cases - not only structural cases - are an unvalued Tense feature on the nominal head D. This extension and the extension of  $\phi$ -features to P heads allows us to use the Tense feature on P in the case assigning process and also allows us to treat all cases uniformly with respect to the features participating in the case assigning relation. As shown in (17), the three heads P, T and Asp bear a valued Tense feature and unvalued  $\phi$ -features at a certain stage of the derivation and can agree with a DP, which gets a case as a consequence of the Agree operation.<sup>9</sup>

(17)

P: val T-f and unval $\phi$ -fs	Agree	DP: unval T-f and val $\phi$ -fs
T: val T-f and unval $\phi$ -fs		
Asp: val T-f and unval $\phi$ -fs		

Biskup (to appear) proposes that the Tense feature on DPs - i.e. cases - can be revalued. This means that a DP can get multiple cases, but since the morphology of Russian and Czech does not allow multiple overt case markers on one element, they are not visible, in contrast to languages like Japanese, Kayardild, Korean or Lardil, which allow more case markers.<sup>10</sup> Thus, in Russian and Czech, the structurally highest Tense value always appears on the particular DP. Let us now look at unprefixing unergative verbs. The derivation of (18a)=(1a) looks like (18b):

- (18) a. Pavel pracuje.  
Pavel.nom works  
‘Pavel works.’  
‘Pavel is working.’

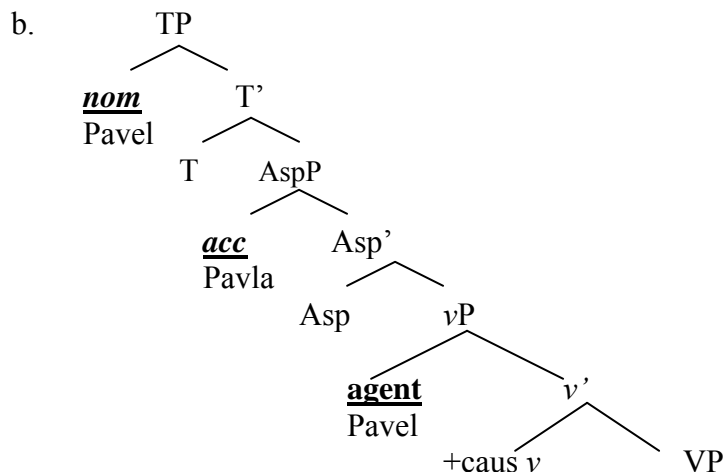

Agent *Pavel*, which is merged in Spec,vP, first agrees with the aspectual head and gets the accusative case. Given the principle of Full Interpretation (19), which states that interfaces must contain only material that is interpretable (valued), unvalued  $\phi$ -features on the head T must also be valued.

<sup>9</sup> The originally unvalued Tense feature on Asp is valued in the course of the derivation. Depending on whether or not a preposition (prepositions bear a valued Tense feature) incorporates into the verb, the verb emerges as perfective (prefixed) or as imperfective (unprefixed).

<sup>10</sup> This means that we do not assume the Activity Condition. Data relying on the Activity Condition then need an alternative explanation.

(19) Full Interpretation (Chomsky 1995, 27)

‘...there can be no superfluous symbols in representations (the principle of Full Interpretation, FI)...’

Thus, *Pavel* also agrees with the head T and its Tense value (case) is revalued. Therefore it is spelled out with the nominative marker.<sup>11</sup> As to the complex scale tree, we get a one-way type of crossing, as illustrated in (20).<sup>12</sup>

(20) Complex scale tree of (18a)

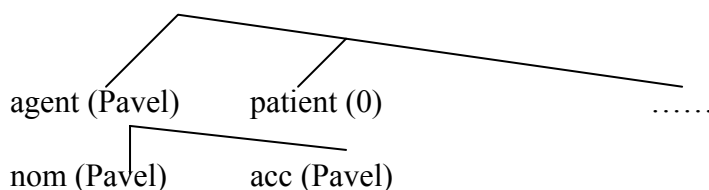

The tree demonstrates that the agent (*Pavel*) is marked by the accusative case, which normally is unmarkedly aligned with the patient theta role; see (13) again. It generally holds, not only for the language system, that a marked value or status is formally expressed (see e.g. Croft 1993 for a language typological point of view). However, there is no special verbal morphology (as e.g. in the case of passives) in (18a) and the argument is marked with the most unmarked case, namely, nominative. The reason for this is that there is no patient theta role in (18a). Thus, in this case, the morphologically unmarked alignment is a result of lacking the patient theta role, the principle of Full Interpretation and the fact that cases (Tense features on DPs) can be revalued.

In the case of unprefixated unaccusative verbs, it works similarly. In (2a), which is repeated here as example (21), patient *opera* bearing the unvalued Tense feature and valued  $\phi$ -features first - given the derivational approach - agrees with the head Asp, which results in the accusative Tense value on *opera*, and then it agrees with the head T and gets the nominative Tense value. Since this is the last (highest) Tense value on *opera*, *opera* is spelled out with the nominative marker.

- (21) Oper-a        hoří.  
Opera-nom    burns  
‘The Opera is burning.’  
‘The Opera burns.’

In the complex scale tree (22), there is again a one-way crossing, now going from the patient theta role to the nominative case; compare (22) with the complex scale tree in (20). As in the unergative example above, there is no special morphological marking on the elements in sentence (21). Here, the reason is that there is no agent theta role, as illustrated in (22).

<sup>11</sup> It is not important here whether or not *Pavel* agrees with the head Asp and T in situ. We put *Pavel* in Spec,AspP and Spec,TP just to show that it is marked by the accusative and nominative case.

<sup>12</sup> For expository reasons, we will put the particular exponents of the case scale and the theta role scale into the complex scale tree (in brackets). Complex scale trees do not have to say anything about whether or not the particular exponents are identical elements; they are meant to represent alignments between cases and theta roles.

(22) Complex scale tree of (21)

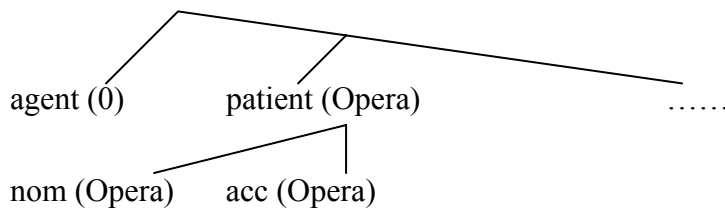

Let us now move to experiencer unaccusative verbs. Given the Binding Principle A asymmetries between the patient and the experiencer argument, we analyze example (23a)=(3a) as shown in (23b).<sup>13</sup>

(23) a. Pavl-ovi se líbil-a ta nová pohádk-a.  
 Pavel-dat self liked-sg.f the new story-sg.f.nom  
 ‘Pavel enjoyed the new story.’

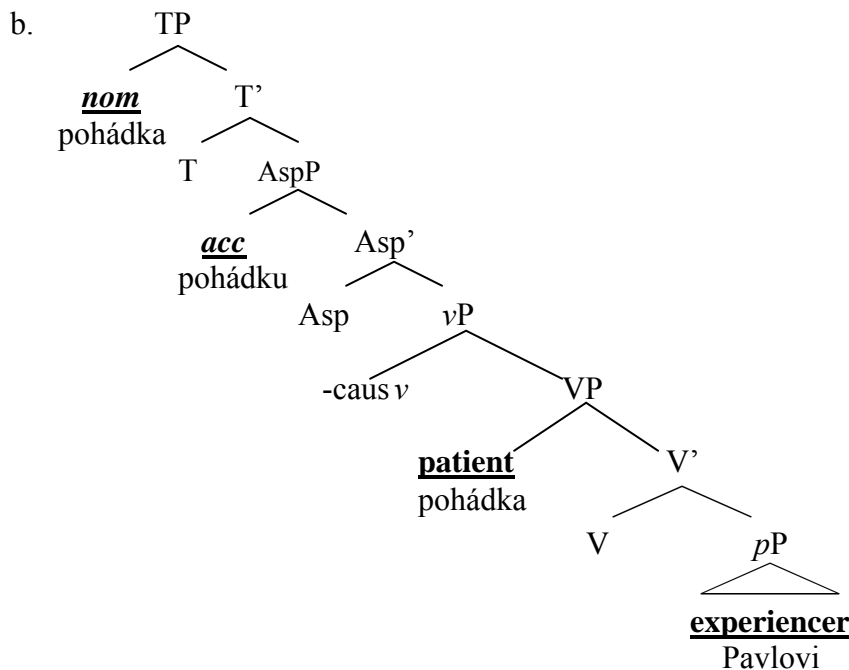

Given the principle of Full Interpretation, unvalued  $\phi$ -features on the heads Asp and T must be valued. This job is done by the patient argument *pohádka*. If all *v*Ps are phases (i.e. unaccusative *v*Ps too) as argued by Legate (2003), then the patient argument must raise to the edge of *v*P. Then it agrees with the head Asp and T, which results in the accusative and the

<sup>13</sup> The following example shows that the patient argument can bind into the dative experiencer (ia) and that in contrast the experiencer cannot bind into the patient (ib), which should be possible if the patient argument were generated below the experiencer. The control example (ic) shows that the ungrammaticality of (ib) is not due to the fact that the possessive reflexive is contained in the nominative argument.

- (i) a. Ten nový student se líbí sv-é profesorc-e.  
 The new student.sg.m.nom self likes self-sg.f.dat professor-sg.f.dat  
 ‘The professor likes his new student.’  
 b. \* Sv-ůj student se líbí profesorc-e.  
 self-sg.m.nom student.sg.m.nom self likes professor-sg.f.dat  
 c. Pavel také vystupuje jako svůj žalobc-e.  
 Pavel.sg.m.nom also acts as self-sg.m.nom accuser-sg.m.nom  
 ‘Pavel also acts as the accuser of himself.’

nominative case, as demonstrated in (23b). The final word order of (23a) is achieved by a topicalization movement of *Pavlovi*. Note that *Pavlovi* precedes the Wackernagel clitic *se*, which is standardly assumed to occur in a head position in the C domain.

It cannot be the dative argument *Pavlovi* that values unvalued  $\phi$ -features on the heads Asp and T. We assume that nonstructural cases like the dative here are prepositional phrases, hence *Pavlovi* in (23a) is a prepositional phrase with a covert preposition, as e.g. in the case of free datives. Biskup (to appear) proposes that the Tense value of the prepositional complement cannot be revalued because prepositional phrases are phases, i.e. *p*Ps (cf. also Abels 2003, who argues that prepositional phrases in Russian and other Slavic languages are phases). Thus, since *Pavlovi* is trapped in the phase complement, then, given the Phase Impenetrability Condition (Chomsky 2000) in (24), it cannot enter into an Agree relation with  $\phi$ -features on Asp and T and its dative case cannot be revalued by the accusative or nominative case.

(24) Phase Impenetrability Condition (Chomsky 2000, 108):

In phase  $\alpha$  with head H, the domain of H is not accessible to operations outside  $\alpha$ ; only H and its edge are accessible to such operations.

The phase status of the prepositional phrase, however, is not the only relevant factor. Since there are phases that allow extraction out of their complement, like e.g. the *v*P phase, another relevant factor is the ability of the appropriate argument to escape the phase. In this respect, we follow Biskup & Putnam (2009), who propose that the prepositional complement cannot be extracted because of the A-over-A principle applied to categories with the bounded Tense feature. Concretely, since P bears a Tense feature with the value bounded and projects the category PP and this category includes the prepositional complement, whose Tense feature has been valued as bounded, the complement cannot move across PP.

The fact that there is a default agreement on the predicate in example (3d), repeated here as (25), shows that prepositional complements (*Pavlovi* and *Praze*) indeed are not accessible for Asp and T and the operation Agree.<sup>14</sup>

(25) Pavl-ovi se libil-o v Praze.  
 Pavel-dat self liked-sg.n in Prague  
 ‘Pavel enjoyed Prague.’

The complex scale tree of (23a) is shown below in (26). One sees the unaccusative one-way crossing combined with the unmarked alignment of experiencer with dative. Since the harmonic alignment of the experiencer theta role with the dative case is unmarked and there is no agent theta role - as in the case of the unaccusative complex scale tree - there is no reason for a special morphological marking.<sup>15</sup>

<sup>14</sup> Dative experiencer constructions like (i), we analyze in the way that the probes on the head Asp and T are valued by the postcopula adverbial, which in fact is nominative DP, as argued by Caha & Medová (to appear).

(i) Mně je zim-a / tepl-o.  
 I-dat is coldness-sg.f.nom warmth-sg.n.nom  
 ‘I am cold/warm.’

<sup>15</sup> *Se* in the predicate *libit se* does not represent a special morphological marking because *libit* cannot occur by itself.

(26) Complex scale tree of (23a)

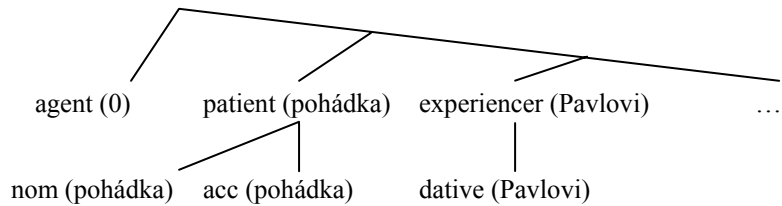

From the syntactic point of view, the morphologically unmarked alignment is a result of lacking the agent theta role, the principle of Full Interpretation and the impossibility of the revaluation of the case on the prepositional complement.

In section 1 we saw that there is also a special class of experiencer verbs taking a nominative patient and an accusative experiencer. These verbs can be analyzed in the same way as the dative experiencer verbs. As to example (27a)=(4a), we just put *Pavla* in the tree in (23b) instead of *Pavlovi* (and change the predicate). As above, the experiencer argument is trapped in the phase complement of the covert preposition, hence its nonstructural accusative case cannot be revalued by the nominative case, and therefore example (27b)=(4b) is ungrammatical.<sup>16</sup> As shown in example (27c)=(4c), in addition to *Pavla* with the nonstructural accusative case, the predicate cannot take another accusative argument, which seems to be counterintuitive. However, unvalued  $\phi$ -features on the head T must also be valued and this results in revaluing the structural accusative on *tu novou pohádku*.<sup>17</sup>

- (27) a. Pavl-a      bavil-a              ta nová pohádk-a.  
          Pavel-acc interested-sg.f    the new story-sg.f.nom  
          ‘Pavel was interested in/enjoyed the new story.’
- b. \* Pavel      bavil              ta nová pohádk-a      / tu novou pohádk-u.  
          Pavel.nom interested-sg.m    the new story-sg.f.nom / the new story-sg.f.acc
- c. \* Pavl-a      bavil-o              tu novou pohádk-u.  
          Pavel-acc interested-sg.n    the new story-sg.f.acc

As for the complex scale tree, we have the same analysis as in the case of dative experiencer verbs; we just put *nonstructural accusative* in the tree instead of *dative*.

### 3.2. Prefixed intransitive verbs

Example (5), repeated here as (28), shows that if the stative predicate *měrz* is prefixed, it can be combined with the resultative prepositional phrase *v ajsberg*. Biskup (to appear) argues that verbal prefixes are a spellout of a P element incorporated into the verb and that the valued Tense feature on the incorporated P element values the unvalued Tense feature on the

<sup>16</sup> Similar accusative experiencer verbs can be found in other languages, too, see e.g. *interessieren*-type verbs in Sternefeld (2006) for German or Pesetsky (1995) for some other languages.

It is necessary to differentiate between experiencer *bavit*, as in (27a), and agentive *bavit*, as shown in (i). In contrast to (27a), the accusative in (ia) is structural, therefore passivization is possible (ib).

(i) a. Jan-a      bavila      Pavl-a.  
          Jana-nom amuse-sg.f Pavel-acc  
          ‘Jana amused Pavel.’  
      b. Pavel      byl      baven      Jan-ou.  
          Pavel.nom was amused Jana-instr  
          ‘Pavel was amused by Jana.’

<sup>17</sup> As pointed out to us by Marc Richards, our approach predicts that there are no single argument accusative-intransitives, hence constructions like accusative unaccusatives may pose a problem for our analysis. With respect to such constructions, we follow Lavine & Freidin (2002, see also Harves 2006), who propose that T is a  $\phi$ -incomplete head that does not have to enter into an Agree relation with an argument bearing  $\phi$ -features.

aspectual head. It brings about perfectivity, concretely, in the case of (28b), the telic type of perfectivity, which licenses the resultative *pP v ajsberg*.

- (28) a. On mērz (\*v ajsberg)  
 he froze in iceberg.acc  
 b. On v-mērz v ajsberg  
 he in-froze in iceberg.acc  
 ‘He froze in the/a iceberg.’

Since prepositions are standardly analyzed as two-place predicates – as S/N/N or  $\langle e, \langle e, t \rangle \rangle$  or  $\langle l, \langle l, t \rangle \rangle$ , see Bierwisch (1988), Heim & Kratzer (1998), Stechow (2006, 2007), respectively - i.e. they localize the first argument with respect to the second argument, we decompose prepositional phrases into PP and *pP*, following Talmy (1978) and Svenonius (2004). The internal argument is taken by the head P and is called the *ground*, and the external argument, which is called the *figure*, is introduced by the head *p*. The figure argument is the entity that is located, moved or somehow characterized with respect to the ground argument. Hence, (28b) is derived as shown in (29).<sup>18</sup>

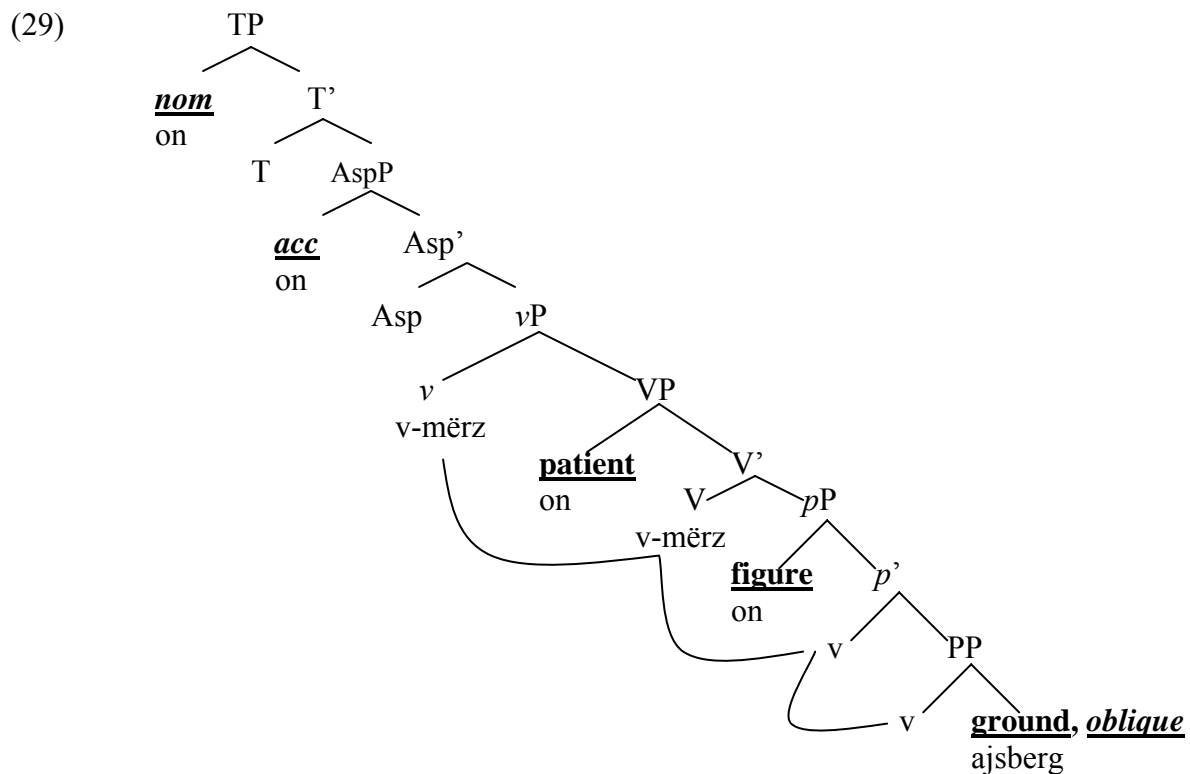

Figure arguments typically get the accusative case (which is revalued by the nominative case in intransitive constructions), hence this is the unmarked harmonic alignment and we put the accusative on the case scale twice, as shown in (30). We assume, see e.g. Hornstein (1999), that arguments can get multiple theta roles and that every subevent must have an argument (Levin & Rappaport Hovav 2004).<sup>19</sup> From the scale point of view, movement (and the

<sup>18</sup> We put *on* in the specifier positions of Asp and T just for expository reasons, to show that it receives accusative and nominative (the same strategy is also used in the following syntactic trees). Here, we are indifferent wrt. the final position of *on*. If every *vP* is a phase, then it is clear that *on* must appear at least at the edge of *vP*.

<sup>19</sup> Given the fact that arguments can bear more theta roles and more cases, it may seem that our approach overgenerates with respect to possible arguments structures. To avoid this complication, we assume in line with

operation Agree) of *on* in the syntactic derivation (29) is represented as the unaccusative type of crossing with the unmarked alignment of figure with structural accusative combined with the unmarked alignment of ground with oblique, as demonstrated in the complex scale tree (30).<sup>20</sup> Given this unaccusative one-way crossing and the two unmarked alignments, we do not observe any special morphological marking in sentence (28b).

(30) Complex scale tree of (28b)

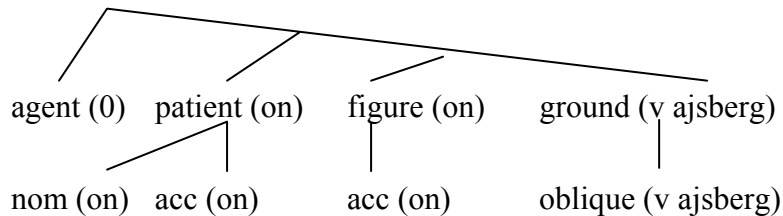

In contrast to the stative verb in (28), the motion verb *echal* can be combined with a directional prepositional phrase, as shown in the following example. Since motion verbs have a path in their meaning, the directional prepositional phrase *v Moskvu* can be mapped onto the path of event *echal* in (31a). In example (31b), the prefix *v-* incorporated into the verb values the Tense feature on the aspectual head, this again brings about the telic type of perfectivity, hence the sentence means that he reached Moscow, in contrast to the imperfective example (31a).

- (31) a. On echal v Moskv-u.  
 he drove in Moscow-acc  
 ‘He was driving to Moscow.’  
 b. On v-echal v Moskv-u.  
 he in-drove in Moscow-acc  
 ‘He drove to Moscow.’

The event of *echal* has an agent and *on* bears the agent, patient and figure theta roles. At the same time, *on* bears the nominative case and the structural accusative case. Consequently, we arrive at the unmarked harmonic alignment of agent with nominative, patient with accusative, figure with accusative and ground with oblique, as demonstrated in the complex scale tree (32). As to the markedness status, the complex scale tree (32) seems to be less marked than the one in (30). A comparison of the complex scale trees (30) and (32) and their appropriate sentences (28b) and (31) confirms that the one-way type of crossing with the missing agent argument plays no role for morphological marking, as we already saw in the case of (20) and (22).

---

Ramchand (2008) that verbs are specified with respect to which subevents they can instantiate and which arguments they license and whether or not the arguments can be identical.

<sup>20</sup> As mentioned in note 12, since complex scale trees are not meant to represent identity between particular exponents on the scales, there is no linking between the patient and the accusative below the figure or between the figure and the accusative below the patient.

From now on, the term *goal* will be replaced by *ground*.

(32) Complex scale tree of (31)

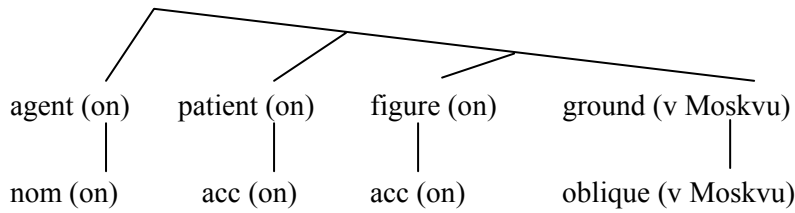

In section 1, we showed that prefixes can also add an argument with structural accusative; consider example (7)=(33) again. Since verbal prefixes are incorporated prepositions, they add a prepositional phrase to the verbal argument structure, which means that they also add new argument positions. This happens in the case of (33b), where *noč* is merged as the figure argument in Spec,*pP*.<sup>21</sup>

- (33) a. On spal (\*noč).  
           he slept night.acc  
       b. On do-spal noč.  
           he to-slept night.acc  
           ‘He slept till the end of the night.’

### 3.3. Unprefixed transitive verbs

We will begin with the unmarked harmonic alignment of transitive verbs; consider example (34)=(8a). Given the Case Filter, every DP must have a case. However, the patient argument *Jirka* is not accessible for the head Asp and T because of the Phase Impenetrability Condition (24). Thus, it must be moved by an Edge Feature to the edge of *vP* - more specifically, in accordance with the Extension Condition to the outer Spec,*vP*. In this position, *Jirka* can agree with the head Asp and its Tense feature is valued as accusative. Theoretically, the Tense feature on *Jirka* could be revalued by the head T as nominative – note that *Jirka* is closer to T than *Pavel* - but then *Pavel* would have no case and the derivation would crash because of the Case Filter. Thus, *Pavel* must move. Note that *Pavel* precedes *Jirka* and can be interpreted as scrambled (backgrounded) in sentence (34a). Since scrambled elements take scope over negation and negation is standardly positioned between T and Asp in Slavic, in (34), where no negation is present, *Pavel* scrambles to the specifier position of AspP. Since *Jirka* does not bear a Scrambling feature, in contrast to *Pavel*, it cannot block the scrambling movement. In the scrambled position then *Pavel* agrees with T and gets the nominative case.

- (34) a. Pavel bil Jirk-u.  
           Pavel.nom beat Jirka-acc  
           ‘Pavel beat Jirka.’

<sup>21</sup> The Ground argument is implicit here. Taking into consideration the interpretation and the prefix *do-*, the Ground can be something like *do konca* ‘till the end’.

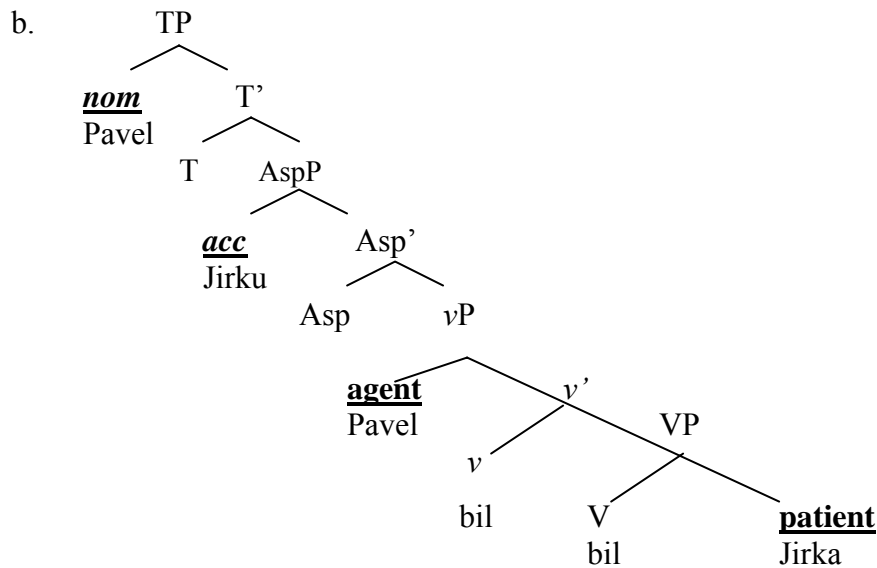

The form of the complex scale tree (35) - i.e., the unmarked alignment of the agent theta role with the nominative case and the patient theta role with the accusative case - reflects the two Agree operations (and movements): between *Jirka* and Asp and between *Pavel* and T, which in turn are determined by syntactic conditions like the Phase Impenetrability Condition and the Case Filter. Since there are two unmarked harmonic alignments, hence no crossing in the complex scale tree, there is no special morphological marking in sentence (34a).

(35) Complex scale tree of (34a)

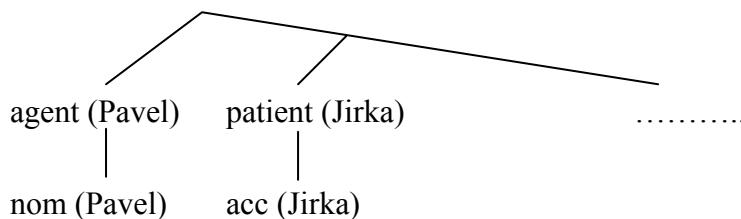

As demonstrated in example (8b), for convenience repeated as (36), the reversed alignment of the agent and patient argument is ungrammatical. The ungrammatical status is due to the violation of minimality principles. Following the argumentation above, in the derivation of sentence (36), the patient argument *Pavel* must move to the edge of *vP* across the agent argument *Jirka*. Then, however, the operation Agree between the aspectual head and *Jirka* (note that *Jirka* is marked by accusative) crosses *Pavel* in the outer Spec,*vP*.

- (36) Pavel      bil    Jirk-u.  
 Pavel.nom    beat Jirka-acc  
 \* 'Jirka beat Pavel.'

The complex scale tree of example (36) looks like (37). There is a two-way type of crossing that is reciprocal. Although (36) is ungrammatical because of the violation of minimality, the example seems to suggest that there is a relation between the reciprocal two-way type of crossing and the ungrammatical status. Generally speaking, it is clear that if two entities interchange their forms, one cannot expect that this state of affairs remains normal. This is not just a language issue; consider e.g. mistaken identity comedies.

(37) Complex scale tree of (36)

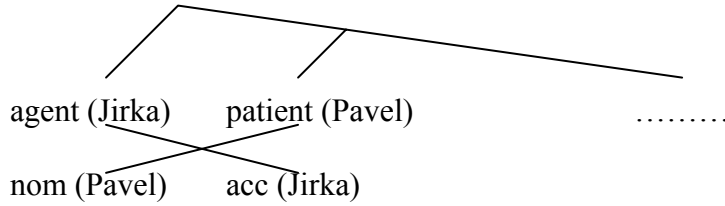

The way out of this problem is to mark the change. It must be somehow repaired. This happens in the case of the passive sentence in (38); therefore it is grammatical.

- (38) Pavel byl bit Jirk-ou.  
 Pavel.nom was beaten Jirka-instr  
 ‘Pavel was beaten by Jirka.’

If you take a look at the complex scale tree (39), you see that the agent argument is marked by the instrumental case instead of the accusative case. Although there is a two-way type of crossing, as in (37) above, the crucial fact is that the crossing is not reciprocal. Note also that the verbal morphology in example (38) is more marked than the one in (36); it is more complex. Compare Greenberg (1966) or Croft (1993), who argue that according to the structural markedness criterion, passives are usually more marked.

(39) Complex scale tree of (38)

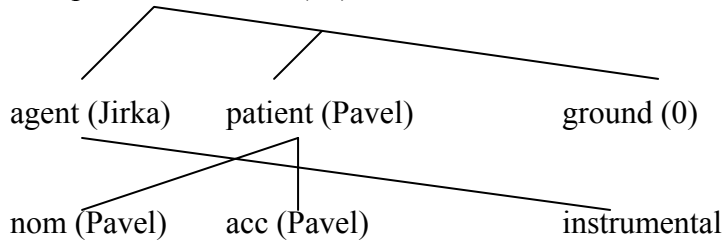

To illustrate why the non-reciprocal two-way crossing is better than the reciprocal two-way crossing (and worse than no crossing in the complex scale tree), let us consider a story from a fancy-dress party. Pavel dates Jana but he is going to part company with her because he just began to be involved with Julie. He knows that at the fancy-dress party, Jana will wear a Snow White mask and Julie a cat mask. Then, in the evening, at the fancy-dress party, Pavel will come to the Snow White and tell her that their relationship is over and then he will tell the cat that he loves her. If the girls wear the right masks - in complex scale words, if there is no crossing - then things went well for Pavel and he can be satisfied. However, if the girls exchange their masks – this is the reciprocal two-way crossing - Pavel will have two problems. Now consider the third scenario, i.e. the morphologically marked case with the non-reciprocal two-way crossing. If Jana borrows Julie’s mask (and her mask stays unused) and Julie borrows a mask from someone else, then Pavel will have only one problem.

Let us illustrate it with another example. Imagine a situation with two trains leaving at the same time and going at the same speed. The first train is going from X to B, the second one from Y to A and both are going on straight railway lines that cross in the middle, as shown by the reciprocal two-way crossing in (14c). In this case, the trains will crash. In contrast, in the case of the non-reciprocal two-way crossing, as shown in (14b), the trains will not crash (if the train from Y to A is not delayed) because the train from X to C must go a longer distance to the crossing point. In the case of the one-way crossing, as demonstrated in (14a), there is even no potentiality for crash because there is only one railway line.

As to the syntactic derivation of example (38), it is important that the agent argument *Jirka* is trapped in the instrumental *pP* phase; therefore its Tense feature cannot be revalued by the heads *Asp* or *T* and it is the Tense feature on *Pavel* that must agree with *Asp* and then with *T*.

Our analysis is supported by the following facts from Philippine languages. Table (40) with the Philippine-type voice system shows that the passive voice is the unmarked alignment and that the ergative case is used instead of the accusative case in the active voice.

(40)

active voice	passive voice
nom/direct (patient)	nom/direct (agent)
ergative (agent)	accusative (patient)

It seems that the situation in the active voice is analogous to the passive example (38). The reciprocal crossing in the Philippine active voice must be somehow repaired, therefore the ergative case - which is often taken to be nonstructural (inherent) case; hence it can be put in the same position as instrumental in (39) - replaces the accusative case, as demonstrated in the following complex scale tree:

(41) Complex scale tree of the Philippine active voice

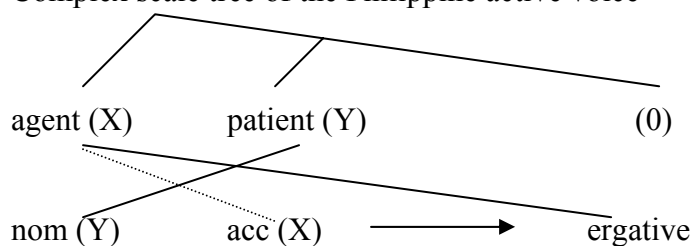

Another support for our analysis comes from Rosen (1990). As pointed out by Fabian Heck (p.c.), Rosen analyzes the person/animacy hierarchy and the case hierarchy in Southern Tiwa in terms of a tiered model reminiscent of autosegmental phonology. What is important here is that according to Rosen, the hierarchy graph with crossing association lines is a prohibited configuration (for a purely syntactic approach, see Heck & Richards, to appear). More concretely, Southern Tiwa does not have clauses like *The snake bit me* with a third person ergative and a first or second person absolutive. Such clauses represent the illicit configuration; consider the hierarchy graph with crossing lines in (42a) from Rosen (1990, 676), which resembles our reciprocal two-way crossing. Instead, Southern Tiwa uses the passive construction *I was bitten by the snake*, which represents the possible configuration; compare Rosen's graph (1990, 676) in (42b).<sup>22</sup>

(42) a.

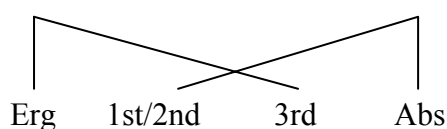

b.

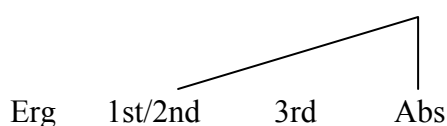

<sup>22</sup> This is in line with the Well-Formedness Condition on association lines in autosegmental phonology. Note that given our mapped complex scale tree, it is not the crossing itself that is illicit but that it is the two-way reciprocal crossing.

### 3.4. Prefixed transitive verbs

We have seen that verbal prefixes are spellouts of a P element, therefore they can add a prepositional phrase to the argument structure if it is not the case that the prepositional phrase is already present there; consider the contrast between (43a) and (43b). Sentence (43b) is represented by the complex scale tree in (44) below. There are four bidirectional unmarked harmonic alignments. The agent theta role is aligned with the nominative case, the patient theta role with the accusative case, the figure argument with accusative and the ground argument with the oblique case. Given these unmarked alignments, we do not observe any special morphological marking in sentence (43b).

- (43) a. \* On v-pisal svoe imja.  
 he in-wrote self name.acc  
 b. On v-pisal svoe imja v knig-u počēta.  
 He in-wrote self name.acc in book-acc of honor  
 'He wrote his name in the book of honor.'  
 c. \* On v-pisal v imja knig-u počēta.  
 He in-wrote in name.acc book-acc of honour

(44) Complex scale tree of (43b)

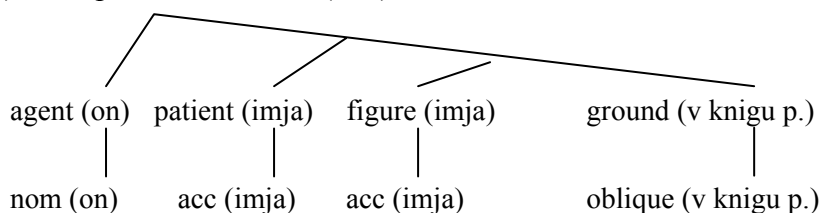

The example (43c)=(9d) demonstrates that the reversed alignment of the figure (patient) argument and the ground argument is not possible. *V imja* cannot be interpreted as the figure and *knigu počēta* with the structural accusative cannot be interpreted as the ground.<sup>23</sup> The complex scale tree of (43c) then looks like (45). We again see the problematic reciprocal two-way crossing (plus the crossing going from the patient theta role to the oblique case and the unmarked alignment of agent with nominative), hence, as expected, the sentence is ungrammatical.

(45) Complex scale tree of (43c)

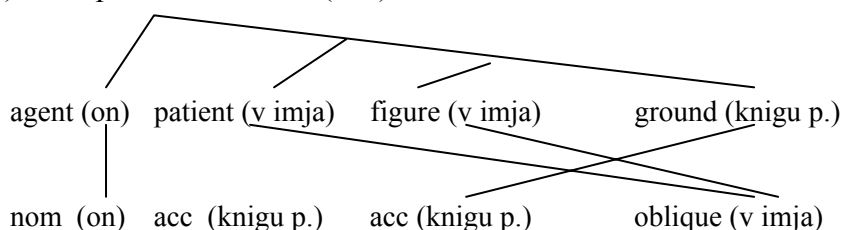

From the syntactic point of view, the problem lies in the fact that there are solid relationships inside the prepositional phrase. Assuming that theta roles are assigned configurationally as a result of the DP-Merger, the argument merged in Spec,*p*P must be the figure and the argument

<sup>23</sup> At first glance, it seems that in cases with more symmetrical arguments the reversed alignment is possible, see (i). In fact, it is not a reversed alignment; the prepositional argument is always interpreted as the ground argument.

- (i) a. He stirred apple sauce into water.  
 b. He stirred water into apple sauce.



- Babby, L. (1987), Case, Prequantifiers, and Discontinuous Agreement in Russian. *Natural Language and Linguistic Theory* 5, 91- 138.
- Bierwisch, M. (1988), On the Grammar of Local Prepositions. In: M. Bierwisch, W. Motsch, I. Zimmermann (eds.), *Studia grammatica* 29. Berlin: Akademie-Verlag, 1-65.
- Biskup, P. (to appear), Prefixes as Prepositions and Multiple Cases. *Proceedings of FDSL-7*.
- Biskup, P. (submitted), P(refixe)s and P(reposition)s. *Proceedings of the 2nd Congress of SLS*.
- Biskup, P. & M. Putnam (2009), One P with two spell-outs: the *ent-/aus* alternation in German. Handout from Roots workshop, Universität Stuttgart, June 10-13.
- Bittner, M. & K. Hale (1996), Ergativity: Toward a theory of a heterogeneous class. *Linguistic Inquiry* 27, 531-604.
- Bobaljik, J. D. (2007), The Limits of Deponency: A Chukotko-centric Perspective. In: M. Baerman, G. G. Corbett, D. Brown & A. Hippisleyet (eds.), *Deponency and Morphological Mismatches*. *Proceedings of the British Academy*, Vol. 145. Oxford University Press, 175-201.
- Bobaljik, J. D. (2008a), Where's Phi? Agreement as a Post-Syntactic Operation. In: D. Harbour, D. Adger & S. Béjar (eds.), *Phi-Theory: Phi features across interfaces and modules*. Oxford University Press, 295-328.
- Bobaljik, J. D. (2008b), From Syntax to Exponence: Some Chukchi Evidence. Handout from Exponence Network Meeting. Leipzig.
- Caha, P. & L. Medová (to appear), Czech Adverbs as Case-marked Adjectives. *Proceedings of FDSL-7*.
- Chomsky, N. (1995), *The Minimalist Program*. Cambridge, Mass: MIT. Press.
- Chomsky, N. (2000), Minimalist Inquiries: The Framework. In: R. Martin, D. Michaels, J. Uriagereka (eds.), *Step by Step: Essays on minimalist syntax in honor of Howard Lasnik*. Cambridge, Mass.: MIT Press, 89-156.
- Croft, W. (1993), *Typology and universals*. Cambridge University Press.
- Demirdache, H. & M. Uribe-Etxebarria (1997), The syntax of temporal relations. A uniform approach to tense and aspect. In: E. Curtis, J. Lyle & G. Webster (eds.), *Proceedings of WCCFL 16*. Stanford: CSLI Publications, 145-159.
- Emonds, J. (2007a), *Discovering Syntax: Clause Structure of English, German and Romance*. Berlin: Mouton de Gruyter.
- Emonds, J. (2007b), Czech Cases and the Syntacticon: Poznámky k, o, okolo, nad něčím a pro někoho. In: M. Dočekal, P. Karlík, & J. Zmrzlíková (eds.), *Czech in Generative Grammar*. München: Lincom Europa, 81-103.
- Forschergruppe 742 (2005), *Grammatik und Verarbeitung verbaler Argumente*. DFG-Antrag. Universität Leipzig.
- Franks, S. (1995), *Parameters of Slavic Morphosyntax*. New York and Oxford: Oxford University Press.
- Greenberg, J. H. (1966), *Language Universals, with Special Reference to Feature Hierarchies*. The Hague: Mouton.
- Hale, K. & S. J. Keyser (1993), On argument structure and the lexical expression of syntactic relations. In: K. Hale & S.J. Keyser, (eds.), *The view from Building 20*. Cambridge, MA: MIT Press.
- Heck, F. & M. Richards (to appear), A Probe-Goal Approach to Agreement and Non-Incorporation Restrictions in Southern Tiwa. To appear in *Natural Language and Linguistic Theory*.
- Heim, I. & A. Kratzer (1998), *Semantics in Generative Grammar*. Oxford: Blackwell.
- Klein, W. (1995), A time-relational analysis of Russian aspect. *Language* 71, 669-695.
- Kozinsky, I., V. P. Nedjalkov & M. S. Polinskaja (1988). Antipassive in Chuckchee: oblique object, object incorporation, zero object. In: M. Shibatani (ed.), *Passive and Voice*. Amsterdam: John Benjamins, 651-706.
- Legate, J. A. (2003), Some Interface Properties of the Phase. *Linguistic Inquiry* 34, 506-516.
- Marantz, A. (2000), Case and Licensing. In: E. Reuland (ed.), *Arguments and Case: Explaining Burzio's Generalization*. Amsterdam: John Benjamins, 11-30.
- Hornstein, N. (1999), Movement and Control. *Linguistic Inquiry* 30, 69-96.
- Levin, B. & M. Rappaport Hovav (2004), The Semantic Determinants of Argument Expression: A View from the English Resultative Construction. In: J. Guéron & J. Lecarme, (eds.), *The Syntax of Time*. Cambridge, MA: MIT Press, 477-494.
- Pesetsky, D. (1995), *Zero Syntax: Experiencer and Cascades*. Cambridge, MA: MIT Press.
- Pesetsky, D. & E. Torrego (2004), Tense, Case, and the Nature of Syntactic Categories. In: J. Guéron & J. Lecarme (eds.), *The syntax of Time*. Cambridge, Mass.: MIT Press, 495-539.
- Pesetsky, D. & Torrego, E. (2006), Probes, Goals and Syntactic Categories.  
[http://web.mit.edu/linguistics/people/faculty/pesetsky/Probes\\_Goals\\_Pesetsky\\_Torrego.pdf](http://web.mit.edu/linguistics/people/faculty/pesetsky/Probes_Goals_Pesetsky_Torrego.pdf)

- Ramchand, G. (2008), *Verb Meaning and the Lexicon: A First Phase Syntax*. Cambridge University Press.
- Rosen, C. (1990), Rethinking Southern Tiwa: The geometry of a triple agreement language. *Language* 66, 669-713.
- von Stechow, A. (1996), The Different Readings of *Wieder* "Again". A Structural Account. *Journal of Semantics* 13, 87-138.
- von Stechow, A. (2006), Spatial prepositions in interval semantics. Ms. Universität Tübingen.
- von Stechow, A. (2007), Schritte für Satzsemantik II. <http://www2.sfs.uni-tuebingen.de/~arnim10/Aufsaeetze/index.html>
- Sternefeld, W. (2006), *Syntax. Eine morphologisch motivierte generative Beschreibung des Deutschen*. Tübingen: Stauffenburg Verlag.
- Svenonius, P. (2004), Adpositions, Particles, and the Arguments they Introduce. *lingBuzz/000042*
- Talmy, L. (1978), Figure and ground in Complex Sentences. In: J.H. Greenberg, C.A. Ferguson & E.A. Moravcsik (eds.), *Universals of Human Language*. Vol. 4. Stanford: Stanford University Press, 625-649.