



www.endogenet.org

Patient Information and Referral Form

PATIENT INFORMATION		REFERRING CLINICIAN INFORMATION	
First name:		Name:	
Family name:		Address:	
or Unique Identification number:			
Date of birth (dd/mm/yyyy):		Email:	
Sex: <input type="checkbox"/> Male <input type="checkbox"/> Female			
Geographic origin of patient:			

DIAGNOSES:

SGA (small for gestational age)
 Postnatal growth retardation
 Overgrowth (prenatal and/or postnatal)

PRENATAL HISTORY:

Maternal age at gestation: __ __ Pregnancies: _ Livebirths: _

Maternal risk factors:

Proteinuria Edema HELLP Obesity Smoking Alcohol
 Diabetes Multiple pregnancy Coombs pos. Hypertension (>140/90)
 others: _____
 Drugs during pregnancy if yes, specify: _____
 Infections (TORCHL) if pos., specify: _____
 Placenta Insufficiency
 reduced placenta perfusion | intrauterine growth retardation

BIRTH HISTORY:

Gestational age: __ __ weeks multiple pregnancy, No of sibs: _

Birth weight: _ _ _ _ g Birth length: _ _ , _ cm Head circumference: _ _ cm

POSTNATAL DEVELOPMENT

Symptoms and Dysmorphic features

Cerebral palsy Mental retardation Motor retardation Clinodactyly
 Visual impairment Hearing impairment Behavioral disorders Microcephaly
 others, please specify: _____

POSTNATAL GROWTH DISORDER

Skeletal dysplasia | Growth hormone deficiency | Thyroid dysfunction
 Chronic organ or inflammatory disease:
 Heart Kidney Liver Lung Intestine Autoimmune
if yes, specify: _____

POSTNATAL GROWTH (BEFORE GH THERAPY)

Date:	_____	_____	_____	_____	_____	_____
Length:	_____	_____	_____	_____	_____	(cm)
Weight:	_____	_____	_____	_____	_____	(kg)

GROWTH FACTORS

Date:	_____	_____	_____	_____	_____	_____
IGF-1:	_____	_____	_____	_____	_____	(ng/ml)
IGFBP-3:	_____	_____	_____	_____	_____	(mg/ml)

GLUCOSE TOLERANCE (GT)

normal GT
 impaired GT
 Diabetes
 not investigated

FAMILY

Please fill out the pedigree drawing below, and give information on height, birth weight and presence/absence of specific abnormalities found in your index patient.

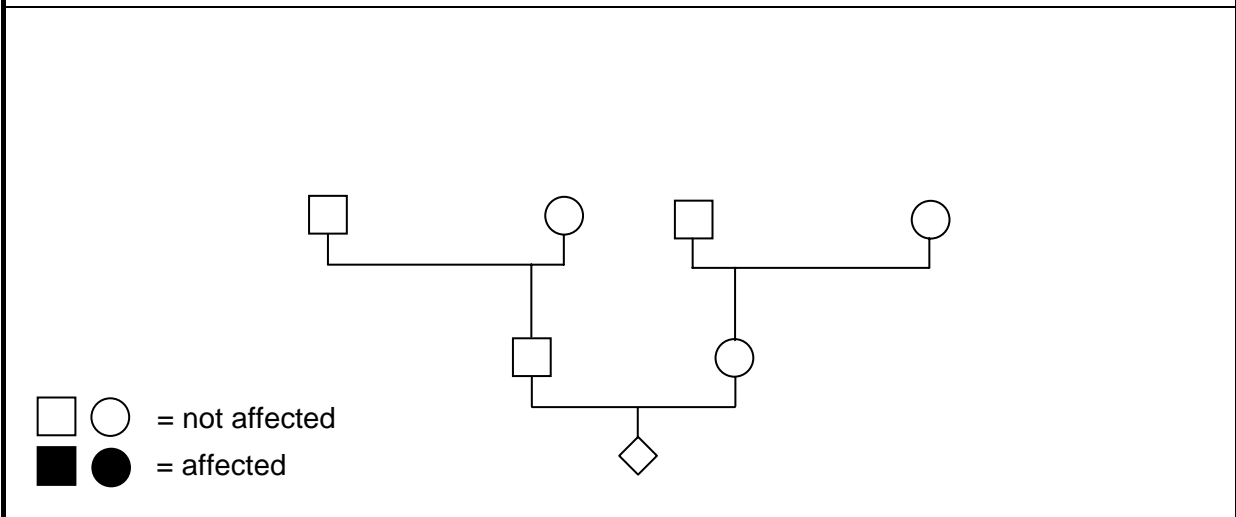

Consanguinity of parents: Yes No Unknown

GROWTH CHART

Please enclose a growth chart with indication of bone age and start and stop of hormone therapy.

HORMONE REPLACEMENT

Please give information about hormone replacement therapy below. For example start, stop and dose of growth hormone

Materials enclosed with this form are:

- Blood sample** (please provide a minimum of 2 ml EDTA, do not freeze)
- DNA sample** (please provide a minimum of 50 µg)
- Skin fibroblasts** (please contact Dr. K. Raile before sending cells)

Clinical Photographs

Pedigree Drawing

Growth Chart

(Good clinical photographs, growth charts and radiographs can be sent by email as JPEGs)

For further instructions on submission of samples and clinical information see our website at www.endogenet.org or contact:

Prof. Dr. Roland Pfäffle

University Hospital for Children and Adolescents

Oststr. 21-25

04317 Leipzig

Tel.: +49-341-9726123

Fax: +49-341-9726349

Email: rpfaeffle@medizin.uni-leipzig.de