

Characterization of a Magnetron Sputtering Source by Rate, Energy and Langmuir Probe Measurements

K. Harbauer, K. Ellmer

- Characterization of sputtering sources
- Multi sensor head
- Deposition rate dependences
- Comparison of a Cu and a W target
- Comparison of Ar and Xe discharge
- Summary

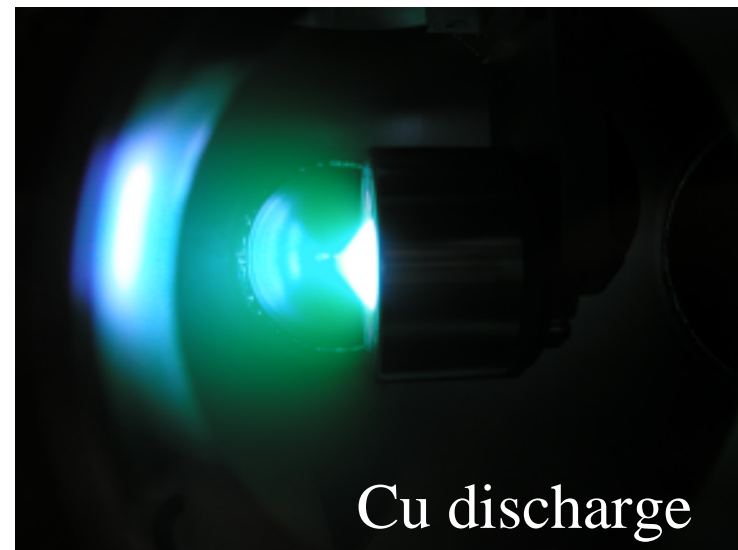

Solare Energetik

Particle Energies in a Magnetron Discharge

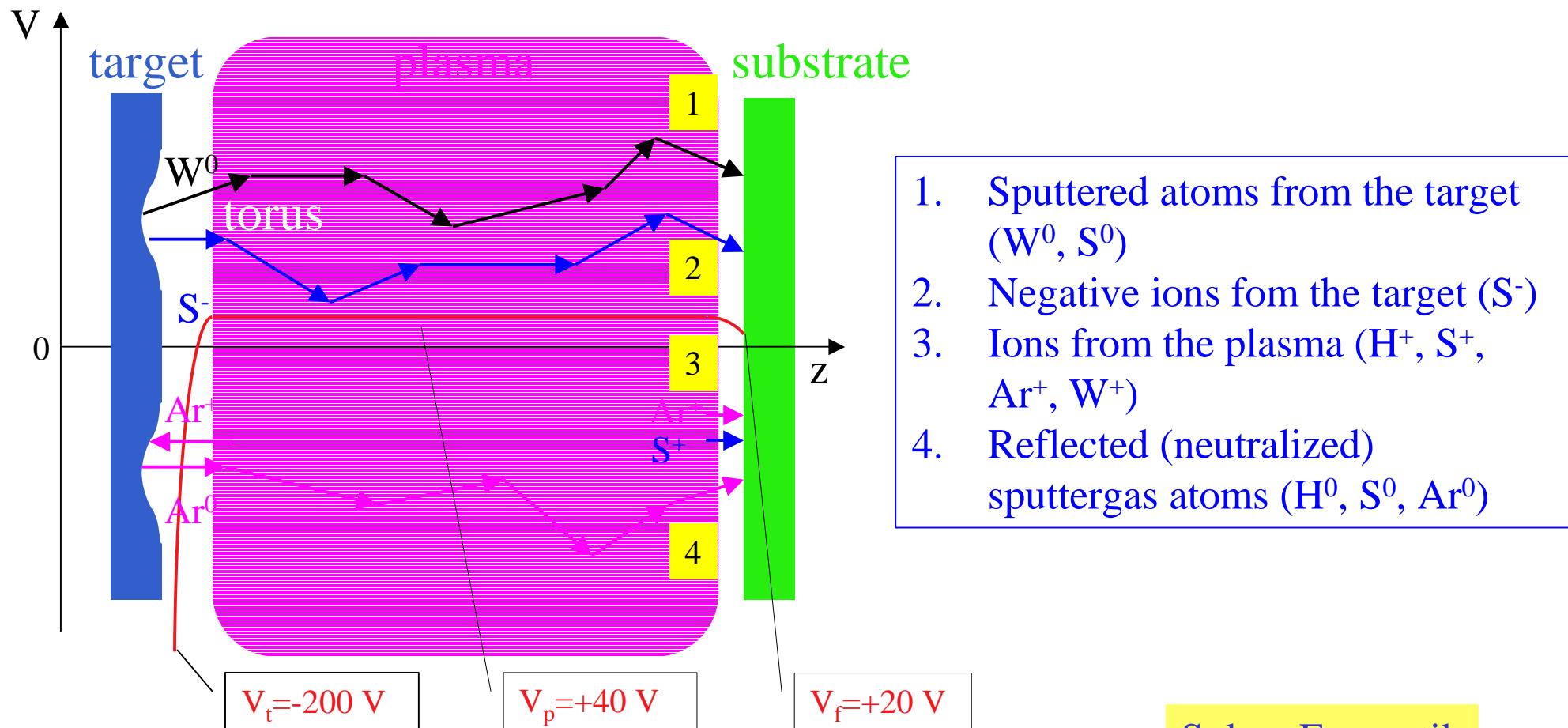

1. Sputtered atoms from the target (W^0, S^0)
2. Negative ions from the target (S^-)
3. Ions from the plasma (H^+, S^+, Ar^+, W^+)
4. Reflected (neutralized) sputtergas atoms (H^0, S^0, Ar^0)

Discharge Pictures of a 51mm Magnetron

Cu target, 50 W, $p_{\text{Ar}} = 0.55 \text{ pa}$

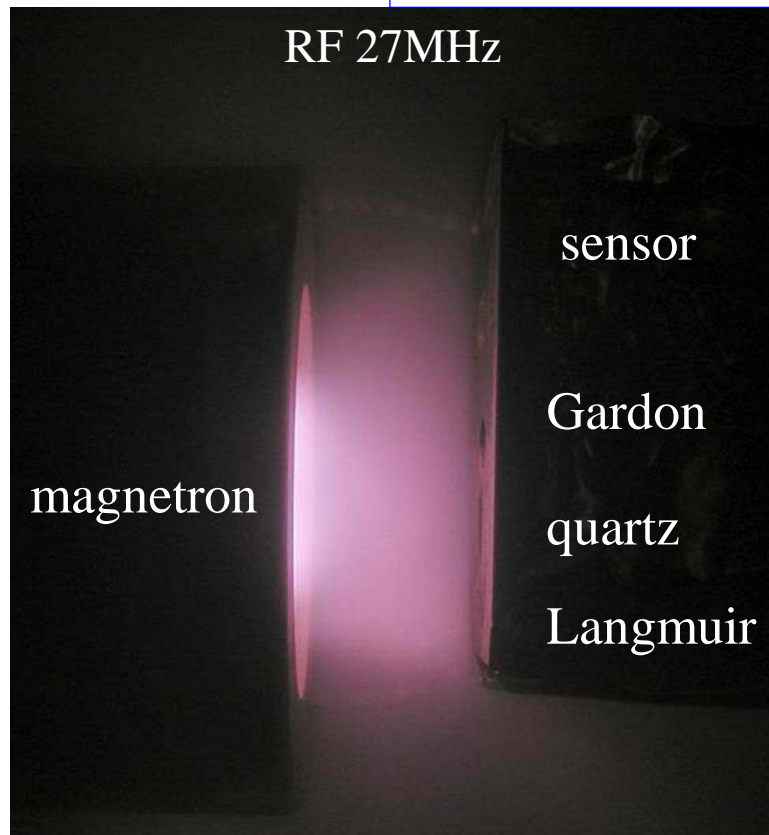

Sensor Front Plate

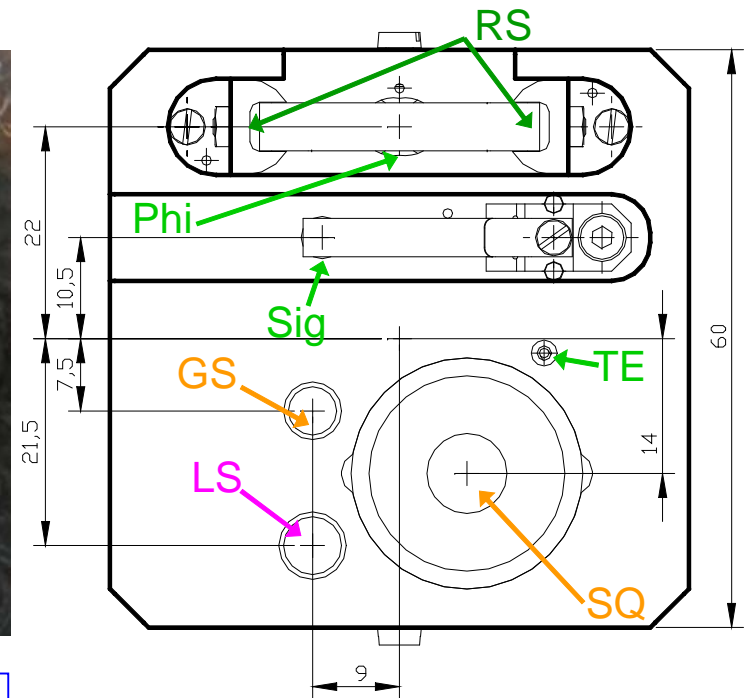
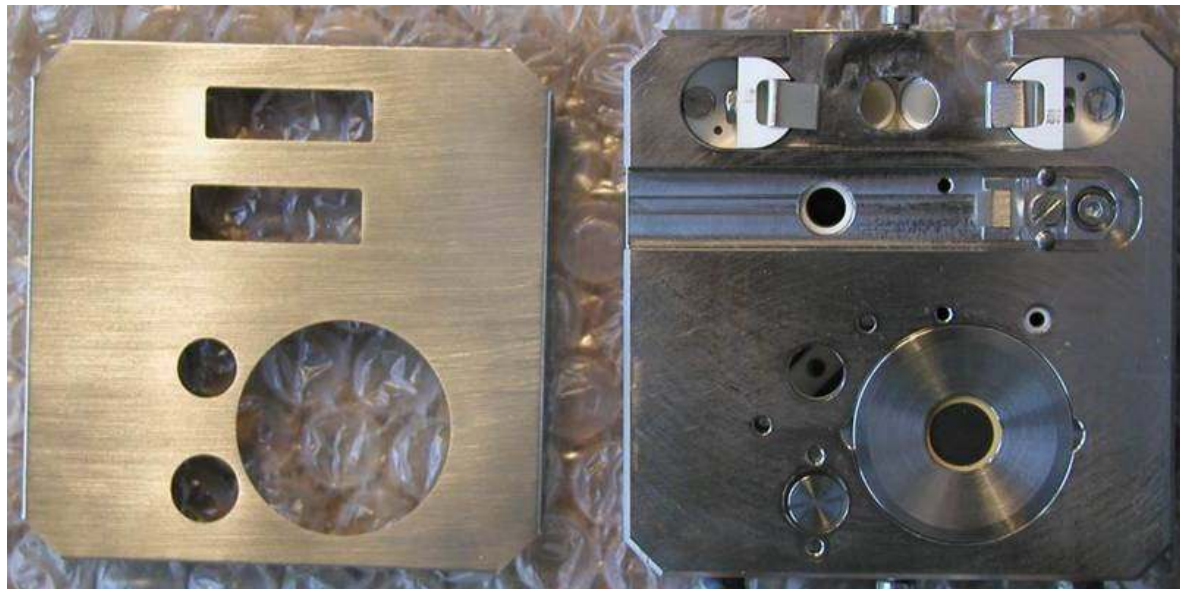

- GS: Gardon sensor
- LS: Langmuir probe
- SQ: quartz crystal monitor
- RS: sheat resistance measurement
- Sig: silicon cantilever

Scheme of the Multi Sensor Apparatus

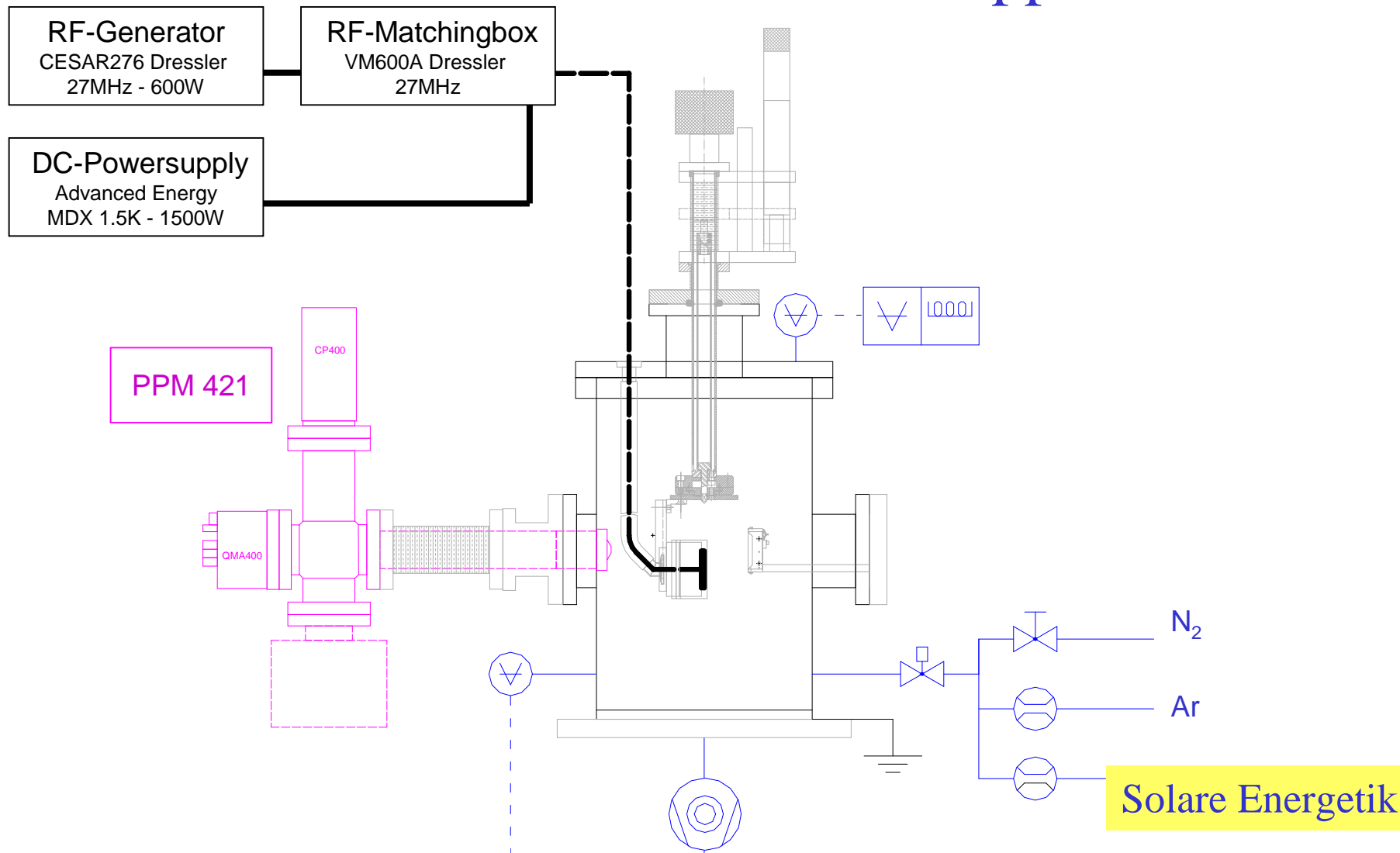

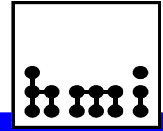

Electrical Scheme of the Multi Sensor

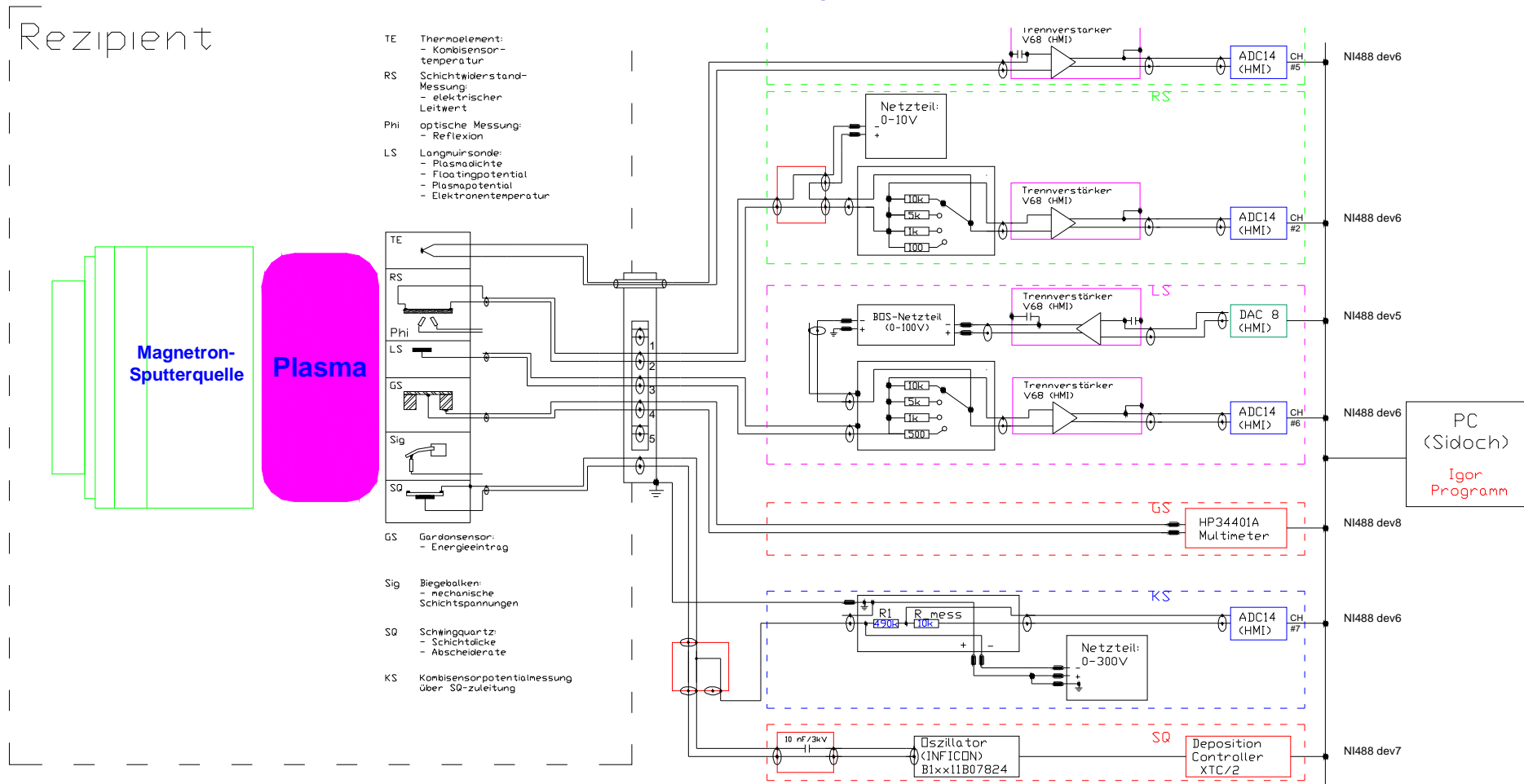

Power Dependence of Rate and Power Input

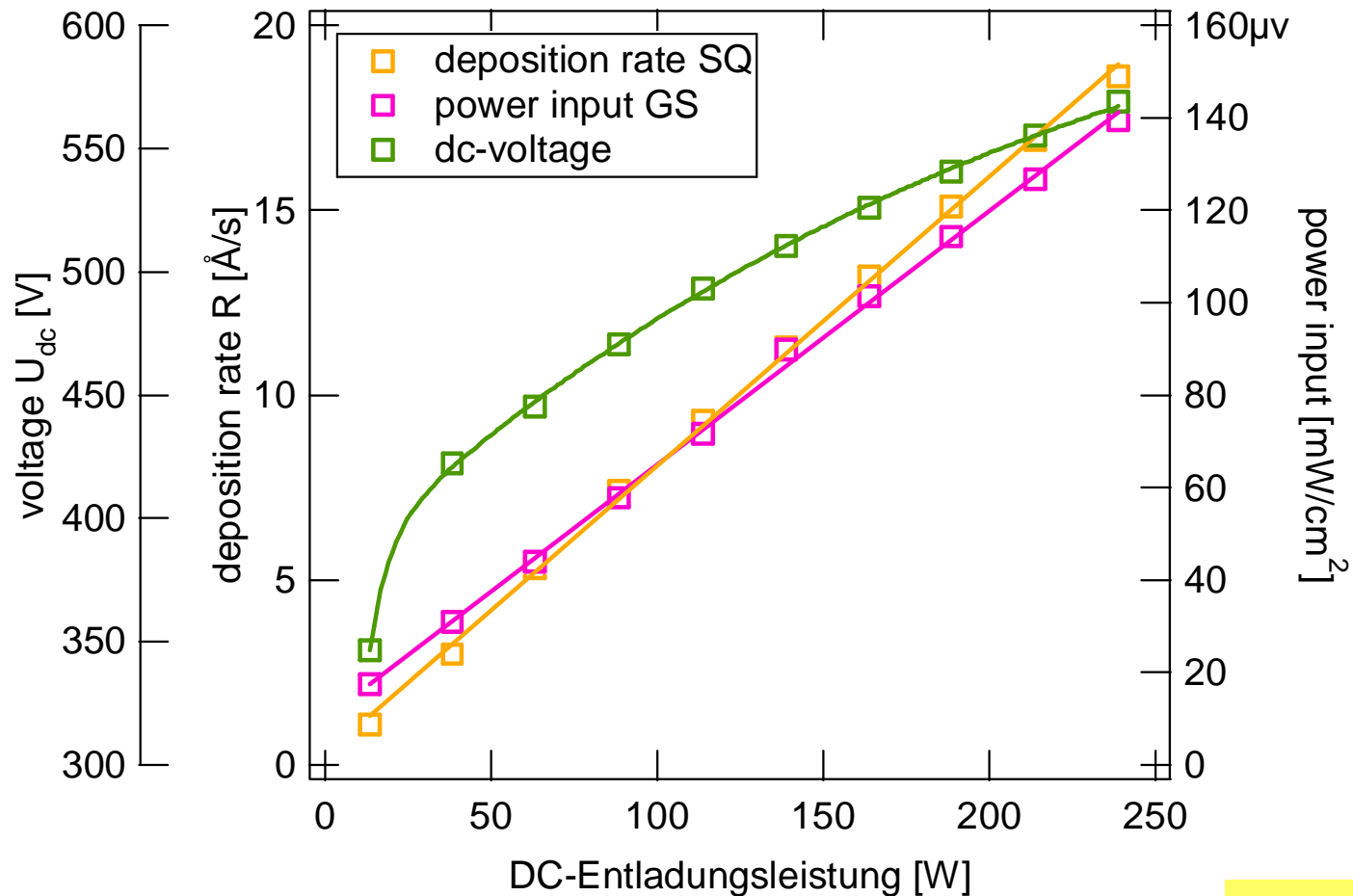

Effect of a Substrate Bias

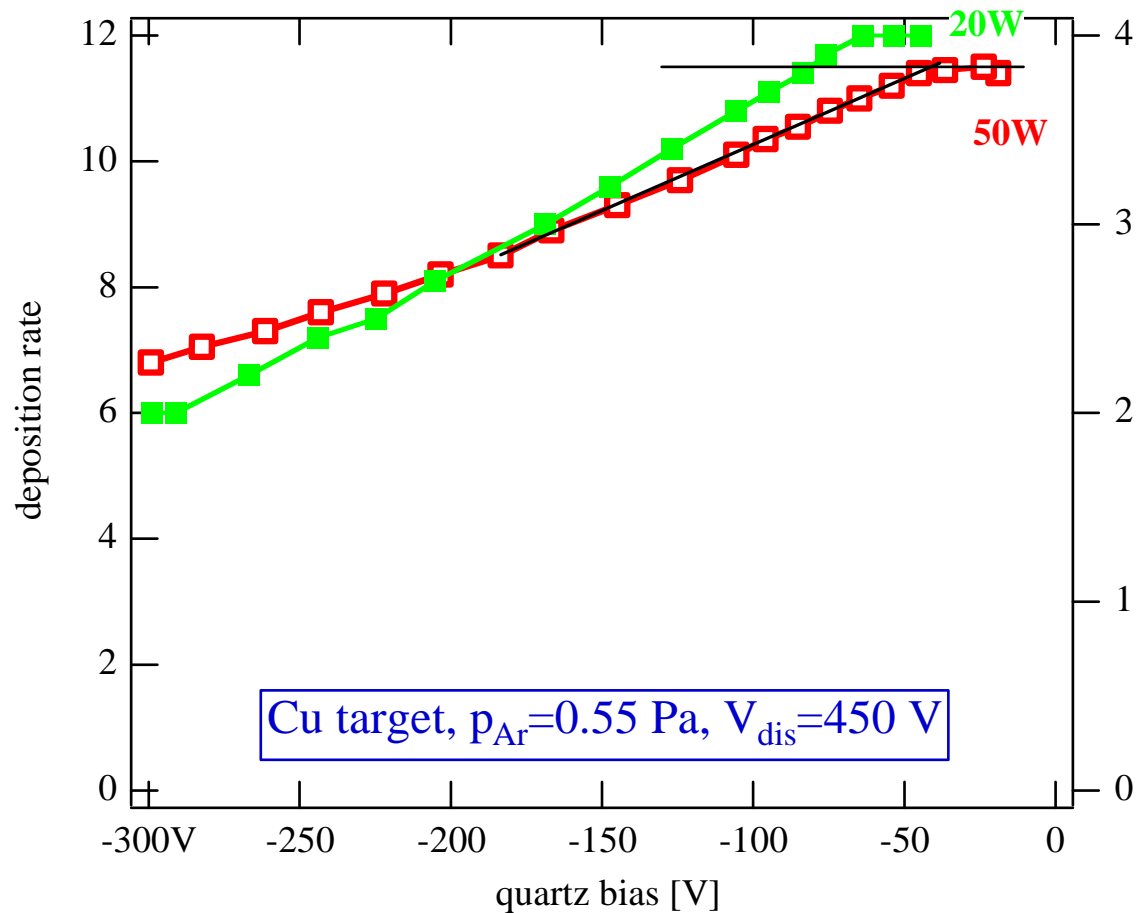

Radial Rate and Power Profiles

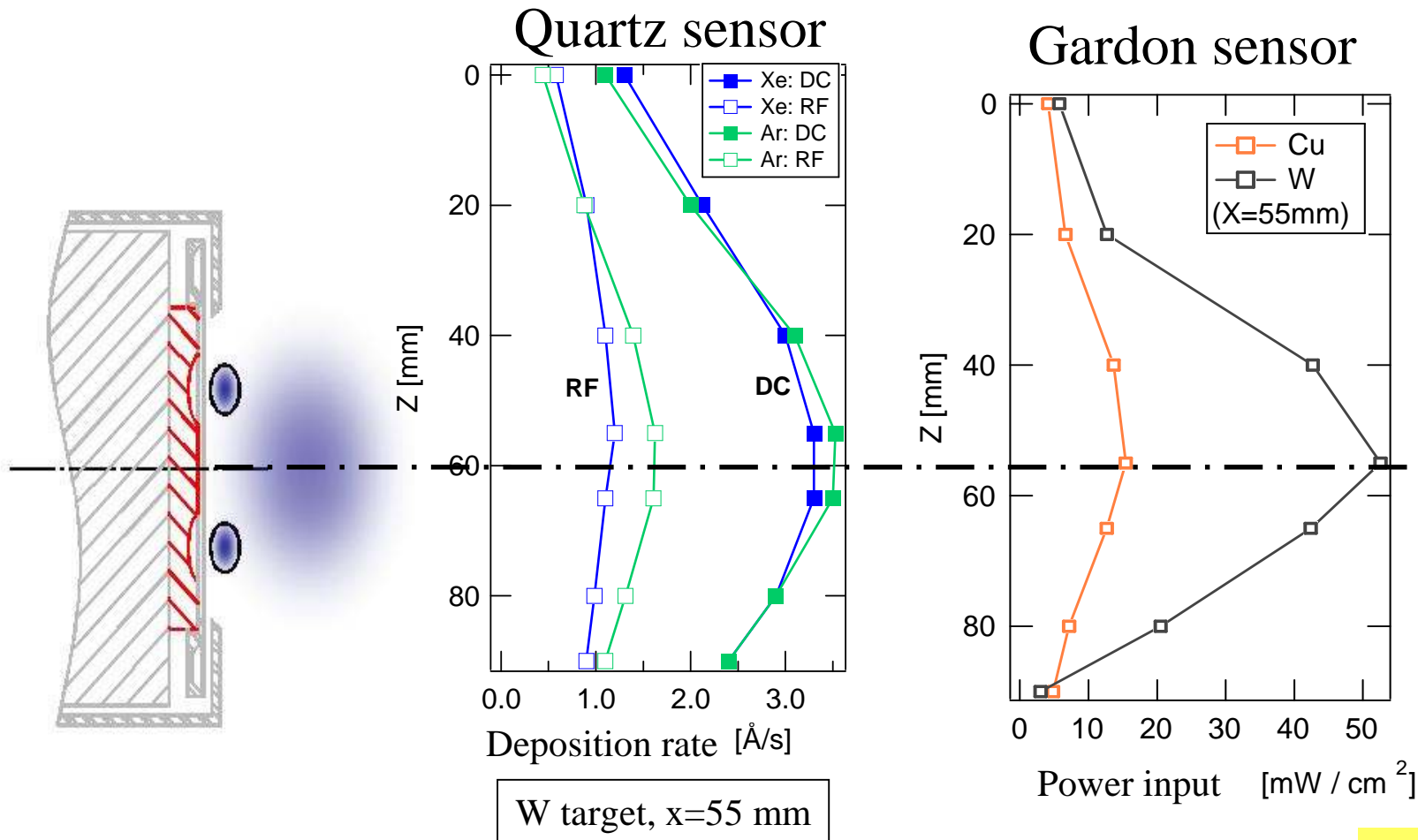

Comparison Cu and W Target

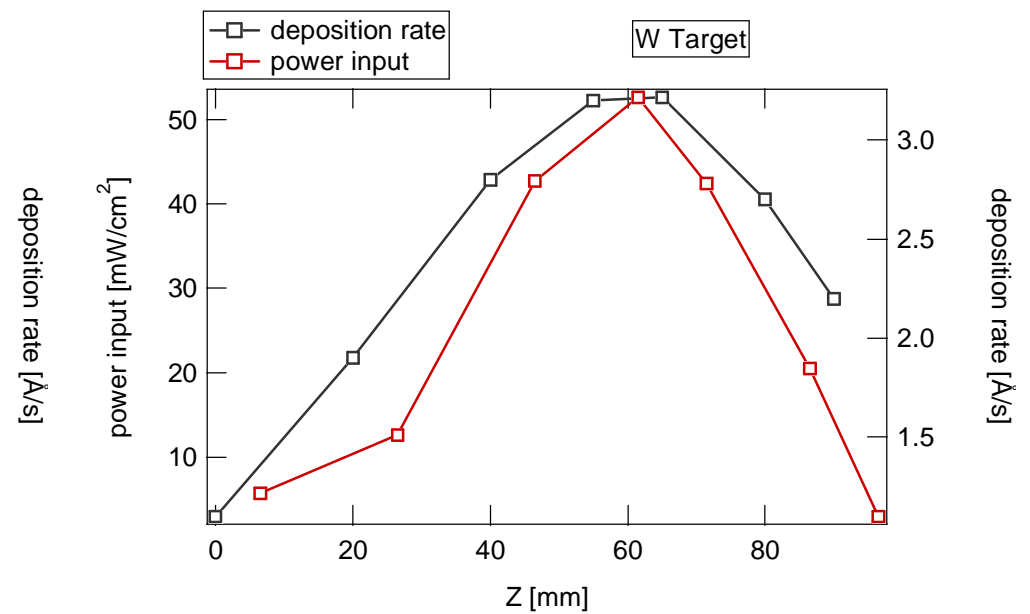
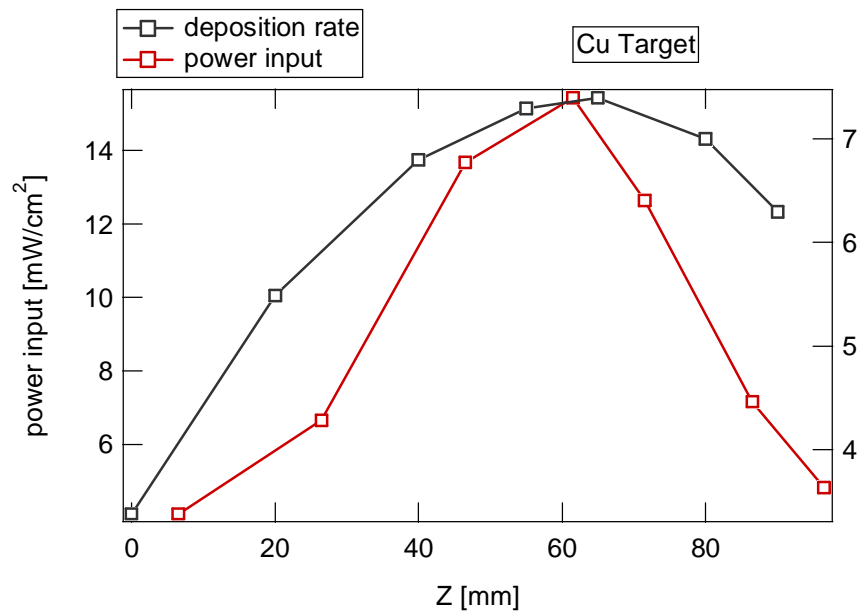

Electron Temperatures for W and Cu Target

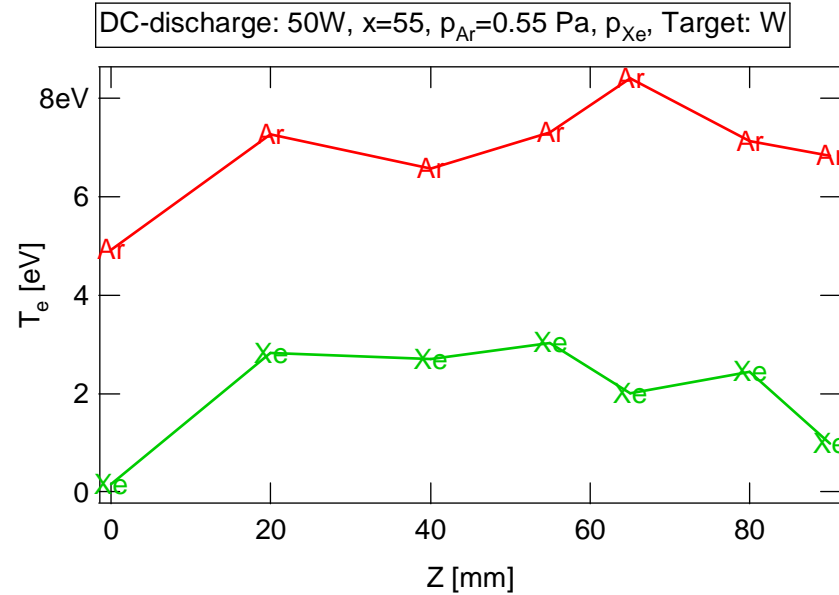
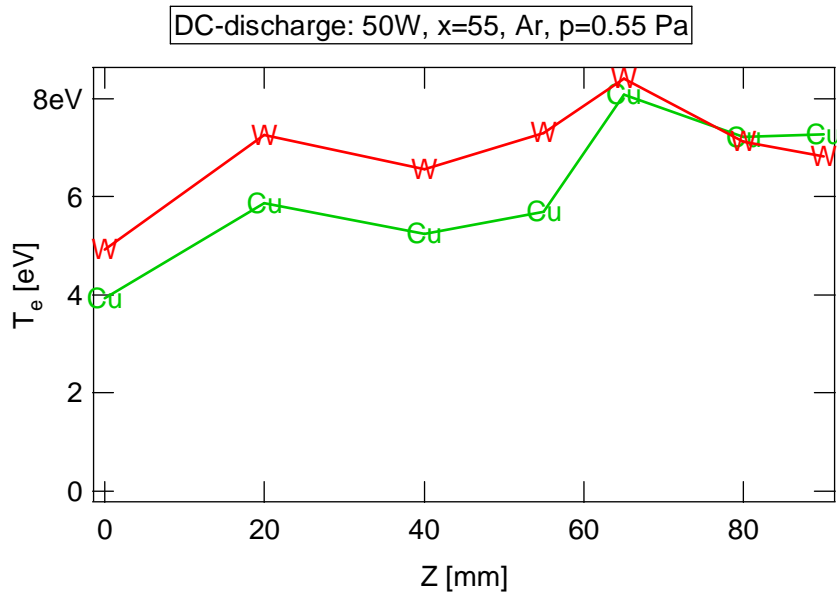

Electron Densities for W and Cu Target

DC-discharge: 50W, x=55, $p_{Ar}=0.55$ Pa, p_{Xe} , Target: W

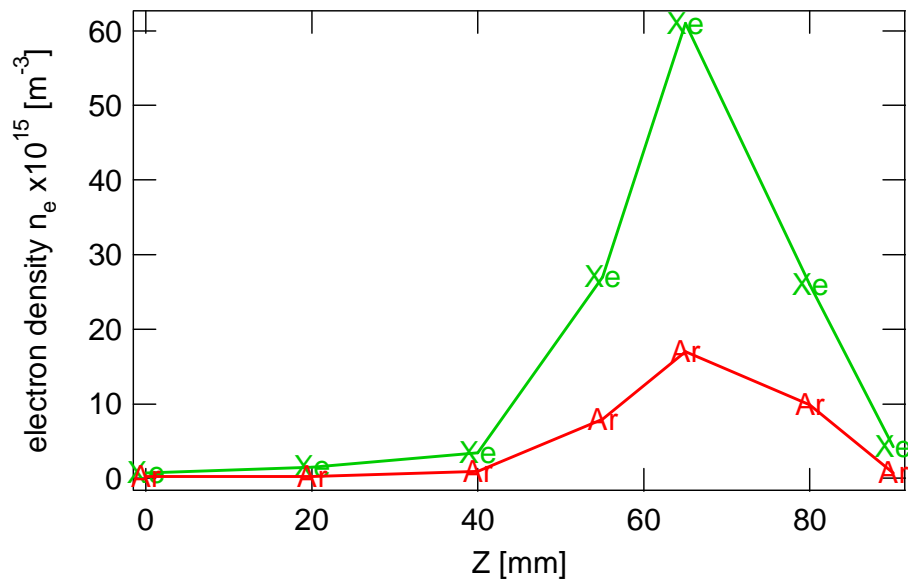

DC-discharge: 50W, x=55, Ar, $p=0.55$ Pa

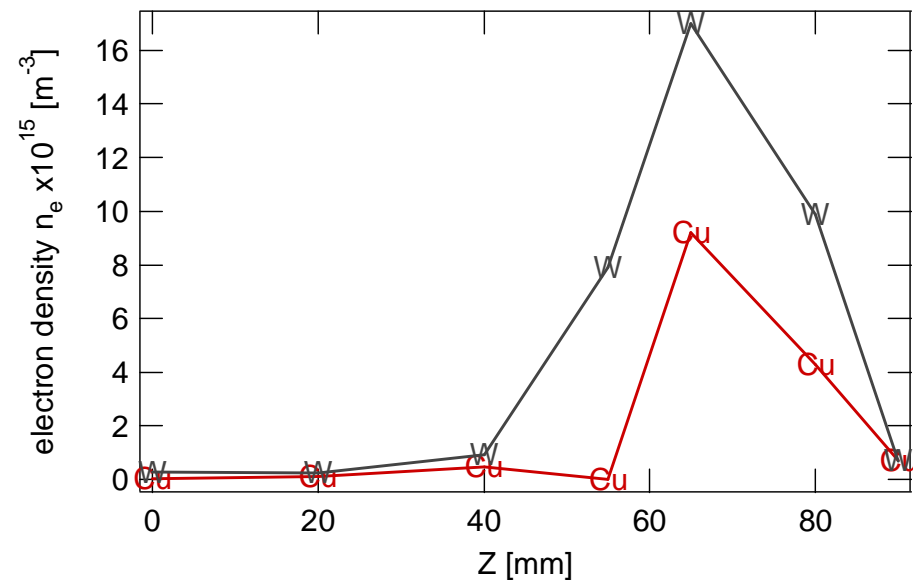

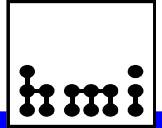

Summary

- A multi sensor head for sputtering source characterization has been constructed and tested.
- The rate-to-power-input ratio is independent on the discharge power.
- For target-to-substrate distances >40 mm, the plasma torus in front of the target can not be resolved.
- This sensor is a good tool for the comparison of sputtering sources.
- In future: Combination with plasma monitor measurements and simultaneous measurement of film parameters

Acknowledgements

- J. Lilie (programming)
- P. Völz (technical assistance)